

OVERVIEW

This electronic switch is a versatile excessive vibration protection instrument. In its standard configuration, the SW6000 is an economical single set point vibration switch loaded with standard features and packaged in an industrial grade housing.

Fully configured, the SW6000 provides for local machine control with optional LCD readout, real time remote operator interface via 4-20 mA and an external BNC (weather-proof only) for easy analyst access to the buffered dynamic vibration signal. Optional hazardous area certifications.

FEATURES

- Low cost, unitized protection system
- Weatherproof/optional ex-proof rated
- Single or optional dual setpoint
- Velocity or displacement response
- Adjustable trip delay
- Setpoint test feature
- Buffered, dynamic vibration signal output for analysis

APPLICATIONS

- Centrifugal Pumps
- Reciprocating Compressors
- Centrifuges
- Cooling Towers
- Industrial Fans
- Electric Motors
- Natural Gas/Diesel Engines

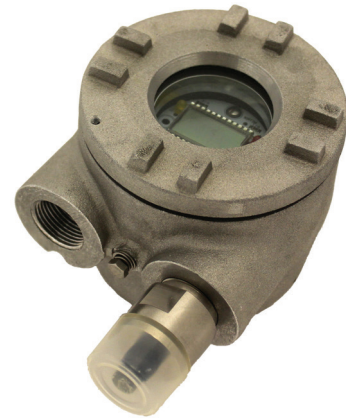

TYPICAL INSTALLATIONS

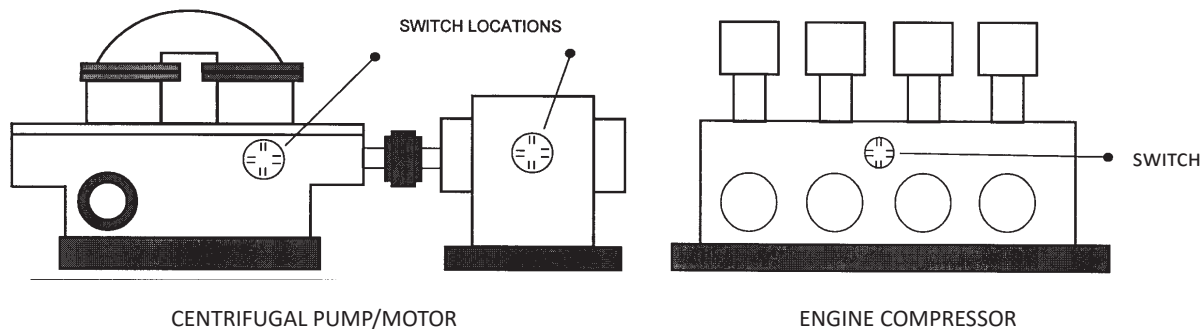

WEIGHT & DIMENSIONS

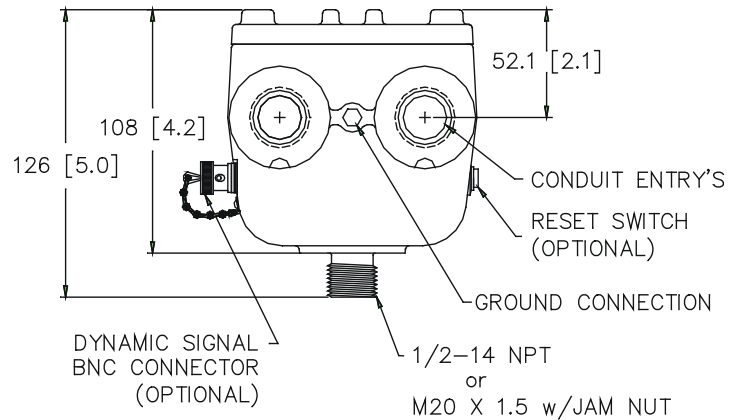
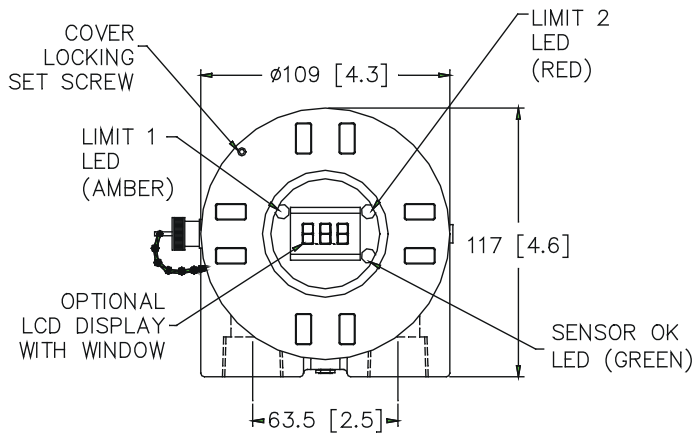

Units: mm [in]
Weight: 2.2 kg [4.4 lbs]

Note:

- 1) Optional BNC connector and weatherproof reset button available only on non-agency approved locations.
- 2) Cover locking set screw on ATEX/IECEx versions only.

SPECIFICATIONS

Sensor	Internal piezoelectric accelerometer
Signal Conditioner	Amplifier/integrator to obtain velocity or displacement response.
Triac Outputs	"A" = 1, 2, 5 or 6; 250 VAC, 1A, optically isolated; standard is N.C. (fail-safe), N.O. field selectable
Maximum Vibration Input	0 to 490 m/sec ² (50 g), peak; 0 to 100 mm/sec (4 in./sec), peak
Frequency Response	<ul style="list-style-type: none"> • Velocity: 2 Hz to 500 Hz • Displacement: 2 Hz to 200 Hz
Adjustable Trip Delay	Factory set at 1 sec.; 1-15 sec adjustable
Temperature Limits	<ul style="list-style-type: none"> • No Display: -40° to +85°C (-40° to +185°F) • W/Display: -10° to +70°C (+14° to +158°F)
Output Sensitivity vs Temperature	Less than .05%/°C (calibrated at 25°C)
Cross Axis Response	Less than 10%
Input Power	Option C <ul style="list-style-type: none"> • Nom. 115 VAC, 95 to 125, 50/60 Hz • Nom. 230 VAC, 190 to 250, 50/60 Hz • Nom. 24 VDC, 20 to 28
Galvanic Isolation	Power from circuit

Optional Buffered, Dynamic Signal Output	Sensitivity: 100 mV/g ±2% @ 25°C. Frequency Response: <ul style="list-style-type: none"> • Acceleration: 2 Hz to 500 Hz • Non-linearity: Less than 1% of full scale (F.S.)
Field Wiring	Maximum wire gauge: 14 AWG; Wire clamp type screw terminal block 500 Vrms isolation from circuit
Housing	Weatherproof aluminum cast
Environmental Rating	NEMA 4/4X
Electromagnetic Compatibility	CE Marked
Optional Hazardous Area Certification	Ordering Options "D"
Optional Display	2½ digit LCD (Ordering Option "A")
Optional FET Transistor Output	50 VDC, 0.5 A, N.C. (fail-safe) standard, N.O. field selectable
Optional 4-20 mA Source Output	Proportional between 4-20 mA with 20 mA set to full scale. Zero and Span calibrated ±2%. Non-linearity < 2%. 600 ohms maximum load resistance.

HOW TO ORDER

A B B C - D E F
SW6000-□□□□-□□□□

A Limits and Displays	
Without Display	
1	one limit, triac
2	two limit, triacs
3	one limit, FET
4	two limits, FETs
With Display	
5	one limit, triac
6	two limit, triacs
7	one limit, FET
8	two limits, FETs

Note: Use triacs in motor starter circuits. FET transistor output(s) recommended for PLC DC inputs.

B	B	Full Scale Range
Velocity Response		
0	1	1.0 in/sec (25.4 mm/sec) peak
0	2	2.0 in/sec (50.8 mm/sec) peak
0	3	20 mm/sec (0.79 in/sec) peak
0	4	50 mm/sec (1.97 in/sec) peak
3	1	1.0 in/sec (25.4 mm/sec) true RMS
3	2	2.0 in/sec (50.8 mm/sec) true RMS
3	3	20 mm/sec (0.79 in/sec) true RMS
3	4	50 mm/sec (1.97 in/sec) true RMS
Displacement Response		
5	1	20 mils, (508 microns) pk-pk
5	2	50 mils, (1270 microns) pk-pk
6	1	200 microns, (7.87 mils) pk-pk
6	2	500 microns, (19.69 mils) pk-pk

C Input Power	
1	115 VAC, single phase, 50/60 Hz
2	230 VAC, single phase, 50/60 Hz
3	20- 28 VDC

D Certifications Local Reset Options	
2	CSA, US/C, Class I, Div 1, Groups B, C & D, T4A, NEMA 4/4X
3	CSA, US/C, Class I, Div 1, Groups B, C & D, T4A, NEMA 4/4X w/ external reset
4	ATEX/IECEX Ex d IIB + H ₂ T4 Gb
5	ATEX/IECEX Ex d IIB + H ₂ T4 Gb with external reset
8	Non-agency approved locations
9	Non-agency approved locations with external reset

E Input/Output Options	
0	No options
2	External BNC for dynamic signal access*
5	4-20 mA proportional to full scale range and separate startup and monitor time delays
7	Options 2 & 5*

* D= 8 or 9 only

F Mounting/Conduit Entries	
0	1/2" NPT stud mount/ 3/4" NPT conduit entry
1	M20 x 1.5 stud mount/ M20 x 1.5 conduit entry
2	1/2-20 UNF stud mount/ 3/4" NPT conduit entry
3	3/4" NPT stud mount/ 3/4" NPT conduit entry

ACCESSORIES

Part Number	7084-001
Name	Flange Mounting Adapter
Description	Stainless Steel adapter for surface mount the SW6000. 1/2" NPT center hole. Three equally spaced 6.6 (.26) diameter mount holes on 38 (1.50) diameter circle
Used with	Any SW6000 with 1/2" NPT stud ("F"= 0)



Weight: 0.5 kg [1 lb]