

## OVERVIEW

The SW5484E is a loop powered seismic velocity transmitter and configurable switch. The compact vibration switch incorporates a piezoelectric accelerometer, signal integrator, RMS or peak detector, 4-20 mA signal conditioner and a digital microcontroller into a single package. It is mounted directly on a machine case or bearing housing without intervening signal conditioning equipment. The switches can be used in an auto-shutdown circuit that trips the machine under high vibration conditions. Two independent configurable alarm setpoints and corresponding discrete outputs allow implementation of ALERT (pre-shutdown) and DANGER (shutdown) levels by the machine control system. A separate 4-20 mA proportional velocity output is also provided, allowing connection to PLCs, DCSs, strip chart recorders, or other process monitoring systems where vibration levels can be trended. The unit comes with 8-Pin M12 Connector or flying leads, and includes the dynamic raw acceleration signal provided through two of the 8 pins.

The 8-Pin M12 Connector comes with a increased safety rating and can be used with barriers for special installations. For explosion proof installations, wire directly to the explosion-proof conduit fittings using the flying lead version with the included elbow.



**8-Pin M12 Connector**  
(Option D=8)  
increased safety



**Flying Leads**  
(Option D=7 and 9)  
increased safety / explosion proof

### \*Explosion Proof Version Option D=7 and 9

**Note: Units sold with an explosion proof rating will include an 8200 explosion proof elbow that will be affixed at the factory.**



### Solid State Relays

The solid state relays included in the switch can carry a maximum current load of 100 mA. If you need a higher current carrying capacity use an interposing relay with a 50 mA holding current like (see example drawing on page 9):

- idc: RSSDN-10A DC Input Solid State Relay
- RSSAN-10A AC Input Solid State Relay
- RU2 Series DPDT Universal Relay

## APPLICATIONS

SW5484E Compact Configurable Vibration Switches are an attractive solution when all the following criteria apply:

- Confined areas such as a cooling tower where people are kept out for safety and disease prevention reasons.
- Water ingress reduced to zero.
- The device can work in any orientation.
- Insufficient room to mount a larger mechanical or electrical switch.
- Capability of switching two independent alarms.
- Field configurable switch setpoints and time delays
- Velocity 4-20mA signal and dynamic raw acceleration output signal are ready for external monitoring and control system

In situations where these criteria cannot be met, Metrix offers other solutions that may be more appropriate, such as vibration transmitters and single-channel monitors that accept an external sensor.



### Seismic Measurements

SW5484E Compact Configurable Vibration Switches are intended for general-purpose seismic vibration measurements on a wide range of rotating and reciprocating machinery with rotative speeds between 120 rpm and 6,000 rpm. Seismic measurements are particularly well-suited for machines that incorporate rolling-element bearings because shaft vibration in such machines is usually transmitted directly through the bearing to the bearing housing, without substantial damping or attenuation. Seismic transducers can also measure vibration that does not originate at the shaft, such as bearing-related wear and defects, footing/foundation problems, piping resonances that are coupled to the machine, etc. Metrix does not recommend seismic measurements as the sole means of protecting machinery with fluid-film bearings where the shaft vibration may not be faithfully transmitted to the measurement location. Thought should be given to the efficacy of such a monitoring strategy before relying substantially or solely upon seismic measurements.

### Why Measure Velocity?

Acceleration and displacement levels are heavily influenced by the frequencies at which the vibration is occurring, while velocity levels are much less influenced. Thus, although acceleration, velocity, and displacement measurements are inter-related mathematically, seismic velocity measurements tend to be more con-

sistent over a wide range of frequencies than either displacement or acceleration. Consequently, broadband (sometimes called “overall” or “unfiltered”) velocity measurements are appropriate for monitoring many machines as a reliable indicator of damaging vibratory energy, with the notable exception of machines with fluid-film bearings, which are usually better addressed by shaft-observing proximity probes.

Casing displacement is not a practical measurement to make directly and is typically just an integrated seismic velocity measurement. As such, the primary decision when selecting a seismic sensor will usually be whether to measure casing velocity or casing acceleration. As noted above, casing velocity will often be more appropriate because it tends to be a more reliable indicator of damaging vibratory energy over a broad frequency spectrum for low- to medium-speed machinery.



**NOTE:** For machines with fluid-film bearings, shaft-observing proximity probes will provide more effective vibration measurements than seismic transducers due to the rotor dynamics of the machine and the attenuation of vibratory energy through a fluid-film boundary. Accordingly, Metrix recommends and provides proximity probes and associated 4-20 mA transmitters or monitoring systems for such applications.

For machines with rolling element bearings and running above 6,000 rpm, and/or where impulsive casing vibration occurs, acceleration may be a better measurement. In such situations, it is recommended that you consult with a Metrix sales professional who can review your application and assist with selection of the proper transducer type and associated transmitter or monitoring system.

## FEATURES

- **Two independently adjustable setpoints** – The use of two setpoints\* (one for ALERT and one for SHUTDOWN) is recommended for applications where it is desirable to remotely annunciate an ALERT condition to operators and/or maintenance personnel. This allows appropriate intervention to occur before the machine reaches SHUTDOWN levels. Switches with only a single setpoint are not capable of pre-shutdown warnings unless the 4-20mA output is connected to a PLC or other trending device, and appropriate pre-shutdown alarm limits are programmed in the PLC.

\* **NOTE:** The two setpoints are set at the factory at one quarter (1/4) and one half (1/2) of the full scale range, and they can both be adjusted through Metrix software.

- **Relay Operation** – The solid state relays of the SW5484E are shipped Normally Open (NO) with a 3 second time delay, which means that when the vibration set point is exceeded three seconds later the relay will shut. If power is removed from the device the relays will remain open. Using the User Software and the Dongle the set points and time delays can be changed. To meet the SIL certification requirements the user must change the relay setting to Normally Closed (NC) using the User Software and the Dongle. NC means that when the SW5484E is energized, or 4-20 mA loop power is provided, the relays are closed. The NC setting is considered “Fail Safe” as the contacts will open on loss of power to the device.
- **Latching Operation** - The solid state relays of the SW5484E are shipped Non-Latching, which means that when the vibration set point is exceeded, and the time delay has expired, the relay will change state. If the vibration level goes less than the alarm setpoint, and Non-Latching is selected for the relay, the relay will automatically change to its original state. If either or both relays are set to Latching, which means that when the vibration set point is exceeded, and the time delay has expired, the relay will change state. If the vibration level goes less than the alarm setpoint, and the Latching mode is set, the relay will not change state until 4-20 mA loop power is momentarily removed to reset the Latched alarms. Latching must be selected for each relay in order to meet the SIL requirements.
- **LOCKOUT (Power-Up Alarm Inhibit) capabilities** – Configurable LOCKOUT capability is available for suppressing alarm activation during transducer startup conditions.

\* **NOTE:** This delay is set at the factory for 10 seconds and can be adjusted in the field by using Metrix software up to 300 seconds.

- **Flexible Discrete Output Types** – The solid state relays can be used as discrete outputs to externally annunciate alarm conditions and to use the switch as part of an auto-shutdown (i.e., trip) circuit. Switches provide two discrete outputs – one for ALARM and one for SHUTDOWN. The outputs can be individually field-configured to have separate time delays and levels. Solid-state relays are designed primarily for applications where the discrete output(s) will be connected to a light load, such as a PLC, DCS or to an interposing relay with a maximum 50mA holding current.
- **Analog 4-20mA output standard** – All switches come with an analog 4-20mA output proportional to vibration velocity

where 4mA = 0% of full scale (no vibration) and 20mA = 100% of full scale. This output facilitates easy connection to PLCs, SCADA systems, and other instrumentation for trending and remote display of vibration values. The “live zero” feature allows users to easily distinguish between no vibration (4mA) and no power or loop discontinuity (0mA). The output also provides its own power, eliminating the need for external 24Vdc loop supplies and allowing use of “sinking” type I/O modules at the PLC, DCS, strip chart recorder, or other instrumentation.

- **Field configurability** – The switch trigger setpoints, time delays and separate shelf states can be field configured for the two alarm setpoints through the use of a communications dongle (Metrix Part #100981).
- **RFI/EMI Immunity** – Enhanced circuit design and installation techniques aggressively minimize noise from common sources such as handheld radios. EMC (Electromagnetic Compatibility) Certificate is available with SW5484E sensors with less than 3-meter cables.
- **Excellent Moisture Resistance** – Hermetically sealed to provide an IP68-rated enclosure.
- **Hazardous Area Approvals** – North American (NRTL), Brazilian (INMETRO), European (ATEX & IECX), and United Kingdom (UKEX) approvals available.
- **Dynamic Signal Availability** – The 4-20 mA velocity-proportional signal is used for easy connection to PLCs, DCSs, and other plant control systems. It also includes the raw acceleration signal (100 mV/g) for use with vibration data collectors and analyzers.
- **Connection Options** – 8-pin M12-type connectors or 8-wire flying leads available.
- **Rugged, Industrial Design** – Robust construction offers outstanding durability; built-in base and housing strain protection helps ensure that over-torqueing sensor-to-machine and sensor-to-conduit connections won’t damage internals or body.
- **High- and Low-Pass Filter Options** – It can be ordered with a wide variety of low- and high-pass filter options to precisely tailor the band over which vibration is measured.
- **Multiple Mounting Options** – Integral and removable mounting stud options available in both metric and English thread sizes; flat base mounting adapters are also available.
- **Loop-Powered** – Runs on nominal 24 V<sub>DC</sub> power supplied by the 4-20 mA current loop.

- **Wide Supply Voltage Range** – Accepts loop power voltages from 11 to 30.0 V<sub>DC</sub> (explosion proof & increased safety).
- **RMS Amplitude Detection** – Measures Root Mean Square (RMS) vibration amplitude. Options available for True RMS or scaled RMS (RMS x √2) for “derived peak”.
- **Numerous Full Scale Ranges** – The full scale ranges provided in option AAA reflect frequently-ordered ranges; however, many others (too numerous to list) are also available. Consult factory for applications requiring other full scale ranges.

## SPECIFICATIONS

All specifications are at +25°C (+77°F) and +24 V<sub>DC</sub> supply voltage unless otherwise noted.

Inputs	
<b>Supply Voltage (see also note under max loop resistance)</b>	11 – 30 V <sub>DC</sub> (24 V <sub>DC</sub> nominal) (explosion proof and increased safety); Metrix patented IPT® independent polarity allows voltage to be connected without regard to polarity.
<b>Circuit-to-Case Isolation</b>	500 Vrms
Outputs	
<b>4-20 mA</b>	Proportional to velocity full scale range (4mA = 0 vibration, 20mA = full scale vibration).
<b>Maximum 4-20 mA loop resistance</b>	$R_L = 50 \times (V_s - 11) \Omega$ where $V_s$ = Supply Voltage at transmitter terminals.  NOTE: For every 50 Ω of resistance in the 4-20 mA loop, 1 V <sub>DC</sub> above the minimum supply voltage (11 V <sub>DC</sub> ) must be available at the transmitter terminals. For example, 12 V <sub>DC</sub> at the transmitter terminals will allow a 50 Ω loop resistance; 30 V <sub>DC</sub> at the transmitter terminals will allow a 950 Ω loop resistance. For special applications, the use of a passive zener barrier will incur a voltage drop of approximately 8.1 volts at the barrier, and the loop supply voltage is limited to 26 V <sub>DC</sub> . Thus, with passive barriers and a 26 V <sub>DC</sub> supply, the maximum available voltage at the transmitter will be 17.9 V <sub>DC</sub> and the corresponding maximum loop resistance will be 345 Ω.
<b>Dynamic Signal</b>	100 mV/g (10.2 mV / m/s <sup>2</sup> ) acceleration, filtered to same frequency band as proportional velocity (see ordering options E & F).
<b>Solid-State Switch</b>	ON/OFF 100 mA maximum current (Continuous) DC Only. If you need a higher current use an interposing relay. See “Solid State Relay” on page one.

<b>Dynamic Signal Output Impedance</b>	10 kΩ  <b>NOTES:</b> 1. The dynamic signal output is short-circuit protected by means of a 10 kΩ resistor, resulting in a relatively large output impedance. Many data collectors and analyzers have relatively low input impedances (100 kΩ or less) which will load this dynamic output and attenuate the signal by 10% or more. Refer to Table 1 for the dB and percentage attenuation for various load impedances.  2. Because the SW5484E is a loop-powered device with low operating power, the dynamic signal output requires a buffer amplifier for cable runs in excess of 30 feet (10 meters). Longer cable runs will also introduce distributed cable capacitance that acts as a low-pass filter, attenuating high-frequency signal content. In such situations, consult the factory for assistance selecting an appropriate low-capacitance cable.
<b>Recommended Minimum Load Impedance (Zload) for Dynamic Signal Connection</b>	500 kΩ (see also note 1 above)
<b>Signal Processing</b>	
<b>Frequency Response (+/- 3dB passband)</b>	2 Hz – 1500 Hz (standard) Optional Low Pass and High Pass Frequency Filters
<b>Optional High-Pass Filter Corner</b>	5, 10, 20, 50, 100, or 200 Hz (must be specified at time of ordering)
<b>High-Pass Roll-Off</b>	12 dB / octave
<b>Optional Low-Pass Filter Corner</b>	230, 250, 350, 450, 500, or 1000 Hz (must be specified at time of ordering)
<b>Low-pass Roll-Off</b>	12 dB / octave
<b>Accuracy</b>	± 3.5% (within passband) ± 5% (at corner frequencies)
<b>Maximum Full Scale</b>	5.0 in / sec (others by request)
<b>Minimum Full Scale</b>	0.5 in / sec (others by request)
<b>Full Scale Range Units</b>	<ul style="list-style-type: none"> <li>• in / sec (standard)</li> <li>• mm / sec (available by request)</li> </ul>

<b>Amplitude Detection</b>	True RMS detector; full scale may be ordered with True RMS units or scaled RMS (RMS x √2) for “derived peak” measurements  See ordering option AAA.
<b>Physical</b>	
<b>Operating Temperature</b>	-25°C to +100°C (-13°F to +212°F)
<b>Weight</b>	0.9 lbs (0.36 kg)
<b>Dimensions</b>	Refer to Figures 1 and 2 on page 8
<b>Sensitive Axis</b>	Same as mounting stud axis
<b>Axis Orientation</b>	Any
<b>Enclosure Material</b>	<ul style="list-style-type: none"> <li>• 316 stainless steel (standard)</li> </ul>
<b>Enclosure Rating</b>	<b>M12-Style Connector (option D=8):</b> <ul style="list-style-type: none"> <li>• IP68 and NEMA 4X</li> </ul> <b>Flying Leads (option=9):</b> <ul style="list-style-type: none"> <li>• IP66 when used with the following elbows: 8200-000 or 8200-000-IEC</li> </ul>
<b>Connector Types</b>	<ul style="list-style-type: none"> <li>• M12 Hermetic Seal Screw-lock (8-wire)</li> <li>• Flying Leads (8-wire)</li> </ul>
<b>Humidity</b>	<ul style="list-style-type: none"> <li>• 100% condensing</li> </ul>
<b>Approvals</b>	
<b>CE Mark</b>	<ul style="list-style-type: none"> <li>• Yes</li> </ul>
<b>Hazardous Areas</b>	<ul style="list-style-type: none"> <li>• NRTL</li> <li>• ATEX</li> <li>• UKEX</li> <li>• IECEx</li> <li>• NEPSI</li> <li>• INMETRO</li> </ul>

ORDERING INFORMATION

AAA-BBCD-EF  
SW5484E-□□□-□□□□-□□

AAA	Full Scale Range <sup>1</sup>		
1	2	1	1.0 in/sec (25.4 mm/s) peak <sup>2</sup>
1	2	2	0.5 in/sec (12.7 mm/s) peak <sup>2</sup>
1	2	3	2.0 in/sec (50.8 mm/s) peak <sup>2</sup>
1	2	4	5.0 in/sec (127 mm/s) peak <sup>2</sup>
1	2	6	0.8 in/sec (20.3 mm/s) peak <sup>2</sup>
1	3	2	3.0 in/sec (76.2 mm/s) peak <sup>2</sup>
1	5	1	1.0 in/sec (25.4 mm/s) true RMS
1	5	2	0.5 in/sec (12.7 mm/s) true RMS
1	5	3	2.0 in/sec (50.8 mm/s) true RMS
1	5	4	5.0 in/sec (127 mm/s) true RMS
1	5	6	0.8 in/sec (20.3 mm/s) true RMS
1	6	2	3.0 in/sec (76.2 mm/s) true RMS
BB	Housing Material, Stud Size & Length <sup>1</sup>		
10	316 SS housing, ¼" NPT stud		
11	316 SS housing, ½" NPT stud		
12	316 SS housing, ⅜ x 24 UNF – ½" stud		
13	316 SS housing, ½ x 20 UNF – ½" stud		
14	316 SS housing, M8 x 1.0 – 12mm stud		
15	316 SS housing, M10 x 1.25 – 12mm stud		
16	316 SS housing, ¼ x 20 UNC – ½" stud		
17	316 SS housing, ¼ x 28 UNF – ½" stud		
18	316 SS housing, M8 x 1.25 – 12mm stud		
19	316 SS housing, ⅜ x 16 UNC – ½" stud		
30	316 SS housing, ½ x 13 UNC – ½" stud		
C	Hazardous Area Certification <sup>3,4,5</sup>		
0	No Hazardous Approval Area		
1	NRTL Class I, Div 2, Grps A-D (increased safety)		
2	NRTL Class I, Div 1, Grps B-D and Class II, Div 1, Grps E-G (explosion proof, includes 8200 conduit elbow)		
6	INMETRO, Ex db 11C T4 Gb (explosion proof, includes 8200 conduit elbow)		
8	ATEX/UKEX/IECEX/NEPSI Ex db IIC T4 Gb (explosion proof, includes 8200 conduit elbow) 16-AV4BO-0213X		
9	INMETRO, Ex ec IIC T4 Gc (increased safety)		
C	ATEX/UKEX Ex ec IIC T4 Gc (increased safety)		
D	IECEX Ex ec IIC T4 Gc (increased safety)		
D	Connection Type <sup>3</sup>		

8	8-Pin M12-Style
7	5 meter (16.5 feet) Flying Leads, 8-wire
9	10 meter (33 feet) Flying Leads, 8-wire
E	High-Pass Filter
0	2 Hz (standard)
1	5 Hz
2	10 Hz
3	20 Hz
4	50 Hz
5	100 Hz
6	200 Hz <sup>6</sup>
X	Custom (consult factory) <sup>7</sup>
F	Low-Pass Filter
0	1500 Hz (standard)
1	500 Hz
2	1000 Hz
3	2000 Hz
4	250 Hz <sup>6</sup>
5	230 Hz <sup>6</sup>
6	350 Hz <sup>6</sup>
7	450 Hz
X	Custom (consult factory) <sup>6</sup>

NOTES:

- Smaller-diameter mounting studs are not able to withstand sustained ambient vibration levels above 2.0 in/sec. Consult Table 2 for allowable combinations of A and B options.
- The SW5484E uses an RMS amplitude detection circuit. Full scale ranges in peak units use scaled RMS (i.e., RMS x √2). The “derived peak” measurements will equal true peak only under the special case of a pure sinusoid, not complex vibration signals.
- Hazardous Area Certifications are not compatible with all connection types. Consult Table 3 for allowable combinations of C & D options. EMC (Electromagnetic Compatibility) Certificate is available with SW5484E sensors with less than 3-meter cables.
- Some approvals require barriers, others require Explosion-Proof wiring practices. Refer to Table 4.
- NRTL/ATEX/UKEX/IECEX/NEPSI Ex d (flameproof) approvals (ordering option C=2, 6, 8, or A) require conduit elbow 8200-00 or 8200-000-IEC, included with assembly. Order reducer if necessary.
- High- and Low-Pass filter corners for standard filters must be separated by at least one octave (low-pass frequency must be at least twice the high-pass frequency). All combinations are allowed except E = 6 and F = 4, 5, or 6. Custom filters with closer separation and/or different roll-offs may be available in some instances. Consult the factory if custom filters are required.

Table 1 – Attenuation of Dynamic Signal versus Load Impedance ( $Z_{load}$ )		
Data Collector / Analyzer Load Impedance ( $Z_{load}$ )	Dynamic Signal Voltage Attenuation (dB)	Dynamic Signal Voltage Attenuation (%)
10 MΩ	0.01 dB	0.1%
5 MΩ	0.02 dB	0.2%
2 MΩ	0.04 dB	0.5%
1 MΩ	0.09 dB	1%
500 kΩ	0.18 dB	2%
200 kΩ	0.43 dB	5%
100 kΩ	0.84 dB	9%
50 kΩ	1.61 dB	17%
20 kΩ	3.57 dB	33%
10 kΩ	6.10 dB	50%

Table 2 – Allowable Combinations for AAA & BB Options	
Full Scale Range AAA =	Allowable BB options (Mounting Stud Sizes)
121, 122, 123, 126, 151, 152, 153, 156	All (no restrictions)
124 and 154	10, 11, 13
132 and 162	10, 11, 12, 13, 15, 19

Table 3 – Allowable Combinations for C & D Options								
D \ C	0	1	2	6	8	9	C	D
8	Y	Y	N	N	N	Y	Y	Y
7	Y	Y	Y	Y	Y	Y	Y	Y
9	Y	Y	Y	Y	Y	Y	Y	Y

Table 4 – Approvals and corresponding wiring requirements				
C	Agency	Approved Areas	Explosion-Proof Wiring Required	I-S Barriers or XP Wiring Not Required
1	NRTL	Class I, Div 2, Groups A-D increased safety		•
2	NRTL	Class I, Div 1, Groups B-D; Class II, Div 1, Groups E-G (explosion proof)	•	
6	INMETRO	Ex db IIC T4 Gb (explosion proof)	•	
8	ATEX / UKEX / IECEx / NEPSI	Ex db IIC T4 Gb (explosion proof)	•	
9	INMETRO	Ex ec IIC T4 Gc (increased safety)		•
C	ATEX / UKEX	Ex ec IIC T4 Gc (increased safety)		•
D	IECEx	Ex ec IIC T4 Gc (increased safety)		•

ACCESSORIES - ELBOWS

Conduit elbows are used with flying leads version of the SW5484E transmitter. They are not compatible with the M12-connector version. A variety of available configurations accommodate English and Metric conduit thread sizes, hazardous area approvals, materials of construction, and IP ratings. Note that not all configurations are available with hazardous area approvals or IP ratings. Table 4 in the datasheet relates what hazardous area (Option C) is allowed per SW5484E Connection (Option D). SW5484E sold with an explosion proof rating (Ex d) will include a 8200-000 or 8200-000 IEC explosion proof elbow and will be affixed at the factory. One can purchase the conduit reducer separately.

8200- **AAA-B**  
-

ELBOWS								
A	A	A	B <sup>2,5</sup>	Conduit Fitting Size	Coating	Approvals	IP Rating (Elbow)	Material
0	0	0		1" NPT	Powder	NRTL <sup>1</sup>	IP66	Copper-free aluminum
0	0	0	IEC	1" NPT	Powder	ATEX/IECEX <sup>3,4</sup>	IP66	Copper-free aluminum
0	0	5		½" NPT	None	None	None	303 stainless steel
1	0	1		¾" NPT	Powder + clear epoxy	NRTL <sup>1</sup>	NEMA4	Copper-free aluminum
1	0	3		½" NPT	Powder + clear epoxy	NRTL <sup>1</sup>	NEMA4	Copper-free aluminum
1	0	8		M20 x 1.5 metric	Powder + clear epoxy	NRTL <sup>1</sup>	NEMA4	Copper-free aluminum



Stainless steel elbows (models AAA=005)



Copper-free aluminum elbows (all models except AAA=005)

8200-000 IEC Reducers			
Part	Description	Material	Rating
91104-032	Reducer, 1"NPT(M) - ¾"NPT(F)	Nickle Plated Brass	ATEX/IECEX
91104-031	Reducer, 1"NPT(M) - ½"NPT(F)		
91104-022	Reducer, 1"NPT(M) - M20 X 1.5(F)		

8200-000 Reducers			
Part	Description	Material	Rating
91104-011	Reducer, 1"NPT(M) - ¾"NPT(F)	Feraloy Iron Alloy	NRTL
91104-015	Reducer, 1"NPT(M) - ½"NPT(F)		
91104-022	Reducer, 1"NPT(M) - M20 X 1.5(F)	Nickle Plated Brass	NRTL

NOTES:

- NRTL approved through manufacturer (not Metrix) for the following areas:  
 Class I, Div. 1 (Grps C & D)  
 Class II, Div. 1 (Grps E, F & G)  
 Class III
- B=IEC is only available for AAA=001, 003, and 008 at this time
- ATEX approved through manufacturer (not Metrix), (B=IEC)  
 CML 16ATEX1325X  
 Ex II2GD, Ex db IIC Gb, Ex tb IIIC Db IP66
- IECEX approved through manufacturer (not Metrix)  
 IECEX QPS 16.0012X  
 Ex db IIC Gb, Ex tb IIIC Db IP66

- UL approved through manufacturer (not Metrix) for the following areas:  
 Class I; Div. 1 (Grps. B, C, D)  
 Class II; Div. 1 (Grps. E, F, G)

\* NOTE: 8200-000-IEC elbow is mandatory for ATEX/UKEX/IECEX/NEPSI Ex d (flameproof) approved installations. The 8200-000 elbow is mandatory for NRTL Ex d (flameproof) approved installations.

## ACCESSORIES - CABLES

	Part Number	Description
	<b>8978-811-0050 or 8978-811-0100</b>	<p><b>8-pin M12 Submersible (IP68) Cable Assembly*</b> Screw-type connector for IP68 rating. 7.62mm (0.3") diameter TPE (thermo-plastic elastomer) jacketed cable encapsulates 4 twisted pairs of 24 AWG conductors and shield. Gold plated contacts, Zinc Alloy with Nickle plated connector body.</p> <p>XXX.X = cable length in meters (example: 0050= 5.0m) <b>NOTE:</b> only 5m and 10m lengths available at this time.</p>
	<b>9334-811-XXXX-YYYY</b>	<p><b>8-pin M12 Armored Cable Assembly*</b> Identical constraints on XXXX and YYYY ordering options.</p> <p>XXX.X = armor length in meters (example: 0035= 3.5 m) Min. armor length: 0.5m Max. armor length: 9.5m Must be ordered in 0.5m increments</p> <p>YYYY = cable length in meters Min. cable length: 1.0m Max: 10.0m Must be ordered in 0.5m increments; <b>NOTE:</b> cable length must exceed armor length by at least 0.5m.</p>
	<b>8201-001</b>	<p><b>Conduit Union</b> Fits between SW5484E and 8200 conduit elbow when there is not enough room to rotate the elbow. Suitable for Class I, Div 1 (Grps A,B,C,D) and Class II, Div 1 (Grps E,F,G) hazardous areas. Material: zinc-plated steel</p>
	<b>7084-001</b>	<p><b>Flange Mount Adapter</b> Adapts 1/2" NPT mounting stud on SW5484E to 3-hole flat-base pattern. Hole pattern is three equally spaced 0.26" diameter holes on 1.5" diameter circle. Adapter is 2" diameter x 0.75" thick. Material: 303 stainless steel</p>
	<b>7084-002</b>	<p><b>Flange Mount Adapter</b> Same as 7084-001 except center hole adapts 1/4" NPT stud on the 5484E-SW.</p>
	<b>7084-005</b>	<p><b>Flange Mount Adapter</b> Same as 7084-001 except center hole adapts 3/8 x 24 UNF stud on the 5484E-SW.</p>
	<b>8253-002</b>	<p><b>1/2" NPT to 1/4" NPT Reducer Bushing</b> Adapts 1/4" NPT stud on SW5484E (B=0) to 1/2" NPT mounting hole. Material: 303 stainless steel</p>
	<b>93818-004</b>	<p><b>Cable Grip Strain Relief Fitting</b> Used primarily with 8978 cable assemblies where cable enters junction box. 3/4" NPT male thread to cable grip. Fits cable diameters from 0.156" to 0.25". Complete with sealing ring and locknut. Hot dip / mechanically galvanized finish. Suitable for NEMA 4 junction boxes.</p>
	<b>93818-018</b>	<p><b>Cable Grip Strain Relief Fitting</b> Similar to 93818-004, but fits larger cable diameters from 0.4" to 0.5", such as customer-supplied cables used with terminal block versions of SW5484E (D = 2 or 3).</p>
	<b>100983</b>	<p><b>Communications Cable Adapter (1 meter)</b> Connects the Communications Cable Dongle (100981) to the 8 pin M12 Style connector D option 8.</p>
	<b>100981</b>	<p><b>Communications Cable Dongle</b> This dongle plugs directly into your computer and then is connected to the SW5484E 4 pin connector.</p>

\*Screw the connector to the switch by turning the tightening nut with green dot. Do not turn the other part of the connector.



OUTLINE DIAGRAMS

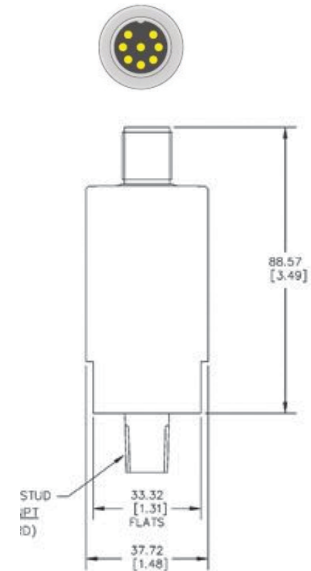
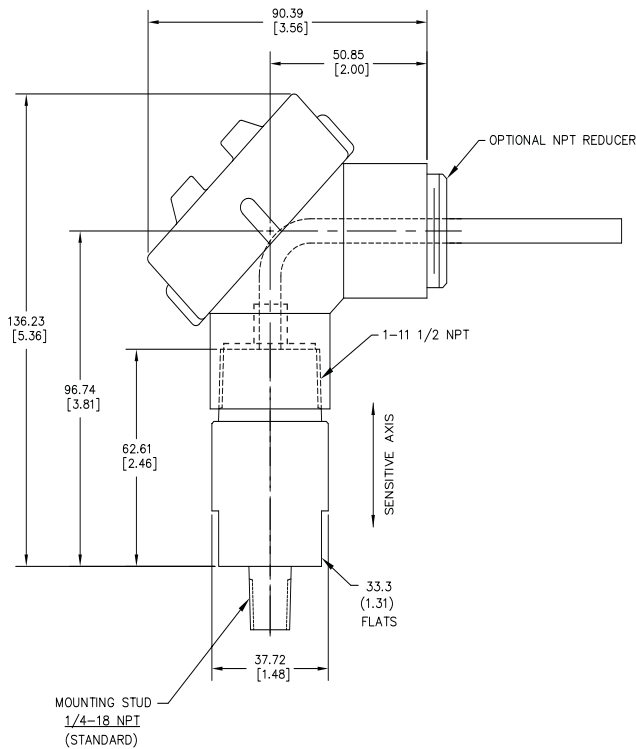
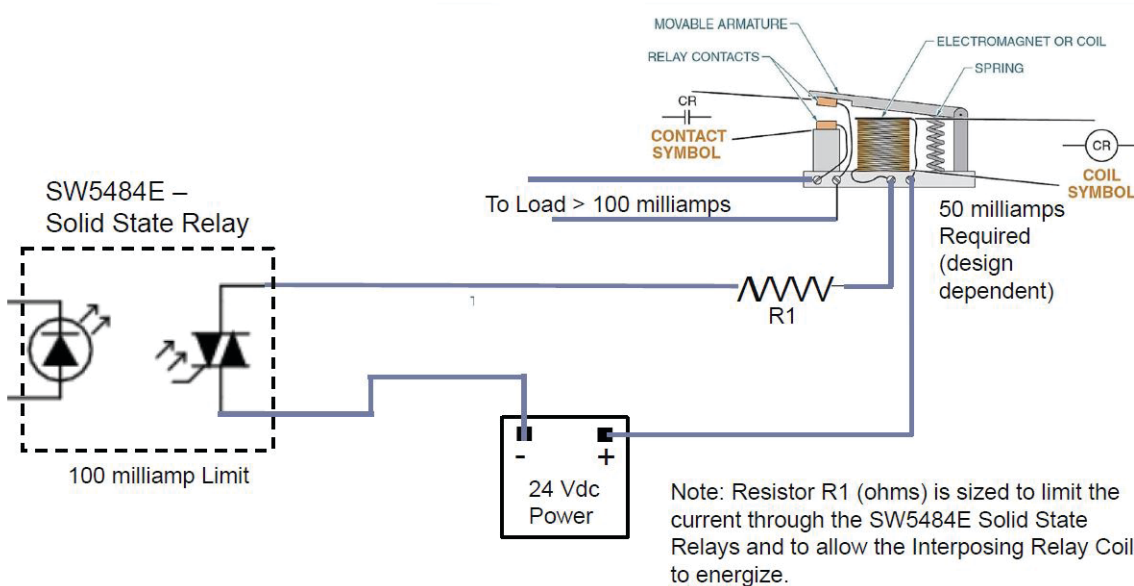

Figure 1: Outline dimensions of the SW5484E Flying Lead Version. Dimensions in mm [inches]. 8200-000 IEC conduit elbow shown installed, necessary for Explosion Proof rating.

Figure 2: Outline dimensions of the SW5484E-XXX-XXX8-XX (M12-Style Connector). Dimensions in mm [inches]. Usually used with non incandive (NRTL) / increased safety (ATEX/UKEX/IECEX) rating, or when no hazardous area approvals are required.

\* NOTE: 8200-000-IEC elbow is mandatory for ATEX/UKEX/IECEX/NRTL/NEPSI Ex d (flameproof) approved installations. The 8200-000 elbow is mandatory for NRTL Ex d (flameproof) approved installations.



Note: Resistor R1 (ohms) is sized to limit the current through the SW5484E Solid State Relays and to allow the Interposing Relay Coil to energize.

WIRING CONNECTIONS

Table 5 – Wiring Connection Legend			
Connect In Type	Color Code	Dynamic Signal Connections	Power Connections
M12 8-Wire	Brown Brown/White Blue Blue/White Orange Orange/White Green Green/White	1 = Switch 1 - 2 = Switch 1 + 3 = Switch 2 - 4 = Switch 2 + 5 = Power + 6 = Power - 7 = Dynamic Signal + 8 = Dynamic Signal -	

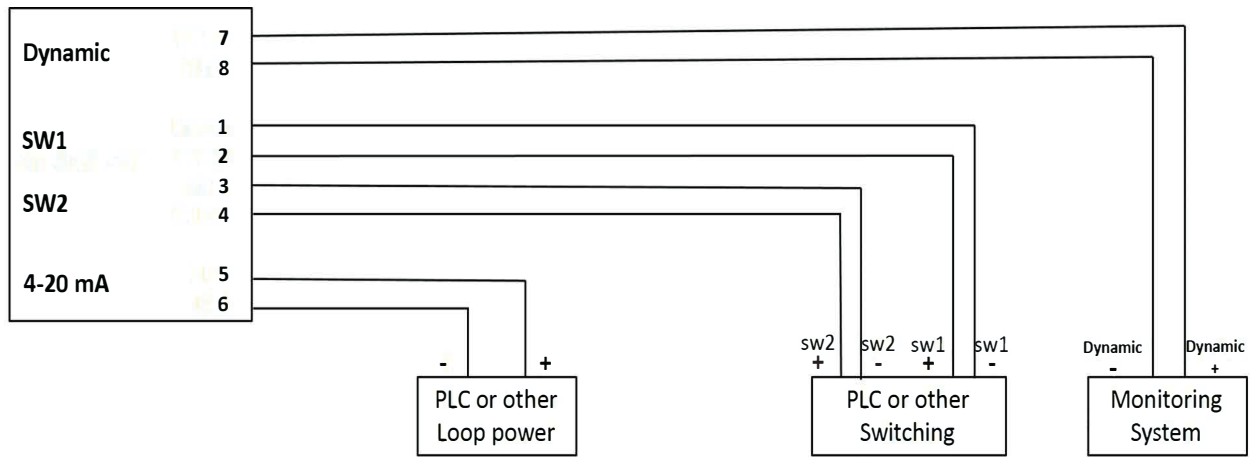

Figure 2: Typical installation for a single SW5484E seismic vibration transmitter.

ADDITIONAL DOCUMENTATION

Description	Metrix Document Number
Manual - General Installation Drawing Included	100982
Installation Drawing – Increased safety	1871697

Trademarks used herein are the property of their respective owners.  
 Data and specifications subject to change without notice.  
 © 2023 Metrix Instrument Co., L.P.