

Application Note	TightView Proximity Probe System	10 May 2016	Rev. A
------------------	----------------------------------	-------------	--------

This Application Note introduces the Metrix TightView™ Proximity Probe System. What this means is that Metrix produces a proximity probe system that can fit in very tight spaces and provide an excellent linear measurement compared to a well-known competitor’s narrow side view product. Typical clearances for our standard proximity probes are as shown:

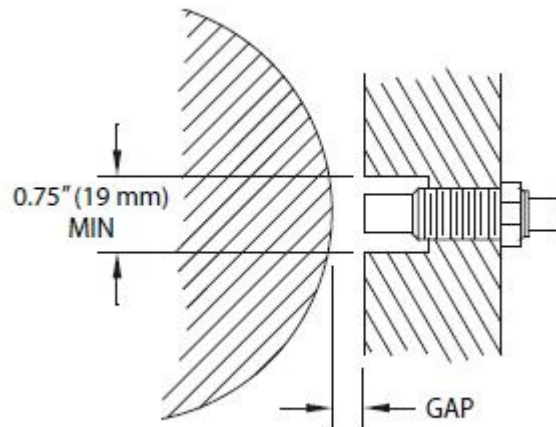

Normal proximity probes usually need at least their probe tip diameter as clearance around the probe tip to ensure an accurate measurement. The above counter bore dimensions, 0.75" (19mm), are typical for a proximity probe to ensure there is no side interference at the probe tip. With the Metrix TightView System, counter bores as small as 0.375" (9mm) can be used and still meet the API 670 linear range requirement. Also, with obstructions that are as tight as 0.05" (2.3mm) from one side of the probe, the API 670 linear range can also be achieved.

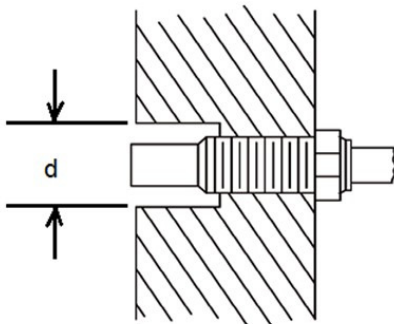

**Using Metrix MX8030 5mm or 8mm Probe  
Counter Bore "d" to 0.375 inches (9mm)**

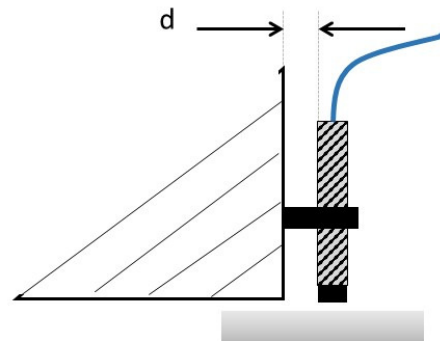

**Using Metrix MX8030 5mm or 8mm Probe  
Obstructed Side View  
"d" to 0.05 inches (2.3mm)**

The following data set shows the Incremental Scale Factor (ISF) for the Metrix (MX) TightView Probe System (5mm Proximity Probe) with various counter bore diameters ranging from no counter bore (open) to a counter bore of 0.375 inches (9mm) against a competitor's narrow side view product. The API 670 specification is a scale factor or 200 mV/mil  $\pm$  5% for an 80 mil range (Note: 200 mV/mil = 0.2 V/mil). Notice that the Metrix TightView Probe System performs very well and is in specification for the range.

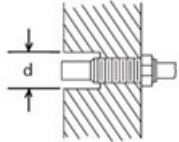

**ISF for a Counter Bore "d" with Metrix (MX) TightView System versus Competitor's Product (CP)**

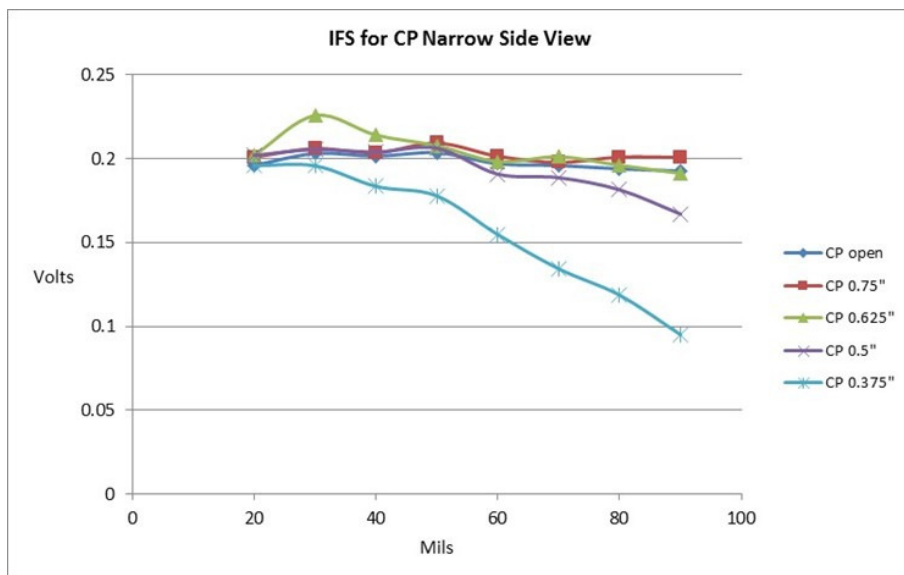
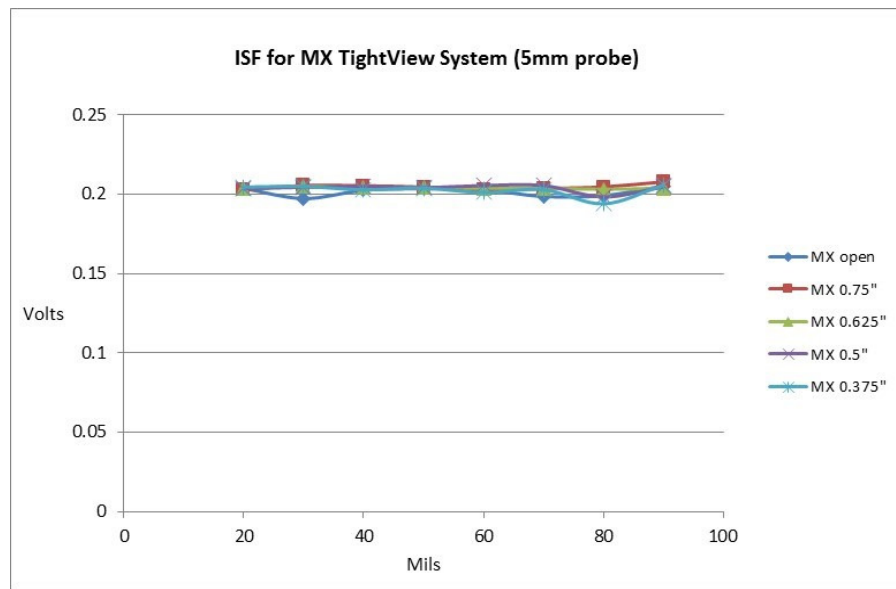

The following data set shows the Incremental Scale Factor (IFS) for the Metrix (MX) TightView Probe System (5mm Proximity Probe) with various obstructed side views from only one side ranging from 0.075 inches (1.9mm) to 0.05 inches (1.3mm) against a competitor's narrow side view product. The API 670 specification is a scale factor or 200 mV/mil  $\pm$  5% for an 80 mil range (Note: 200 mV/mil = 0.2 V/mil). Notice that the Metrix TightView Probe System performs very well and is in specification for the range.

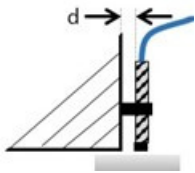

**IFS for Obstructed Side View "d" Metrix (MX) TightView System versus Competitor's Product (CP)**

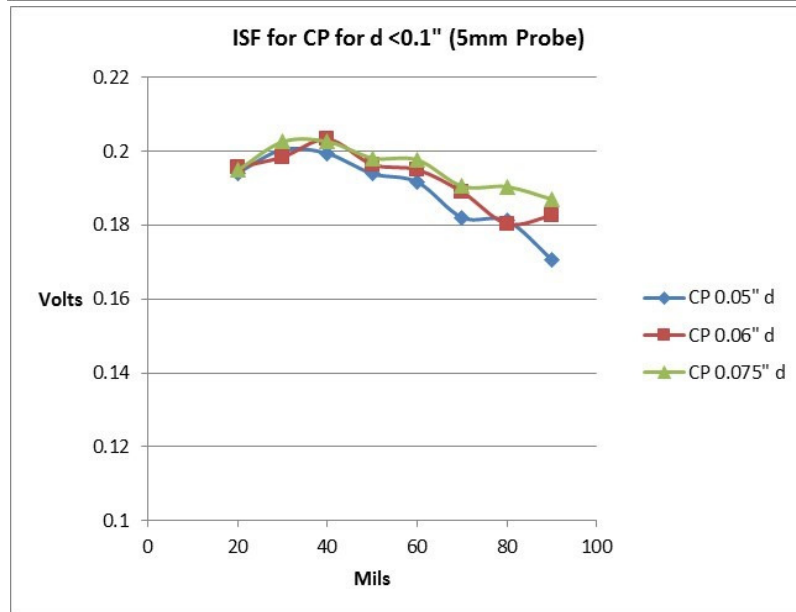
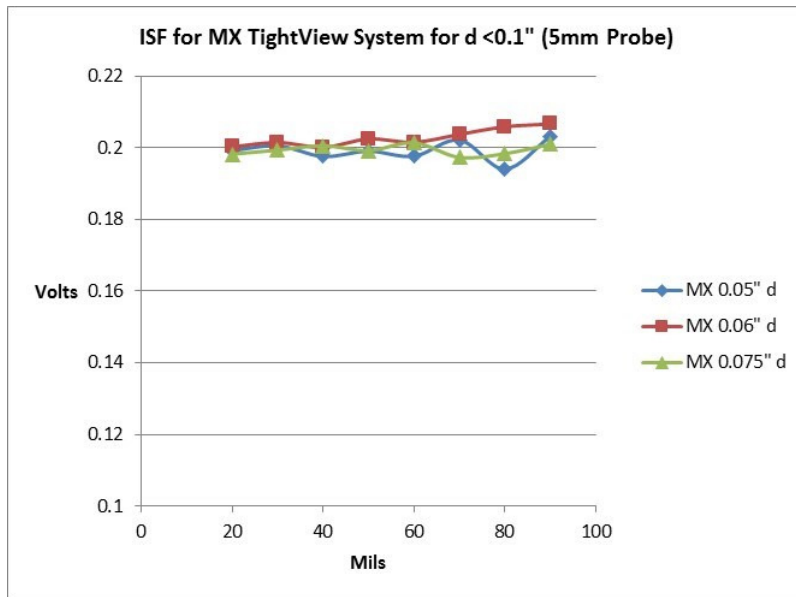

**Installation Variance** - Another interesting feature of the Metrix TightView Proximity Probe System is how the Metrix system holds up with regard to installation variance. This occurs when the 5mm probe is not completely flush with the counter bore or the side obstruction. Like in the view below:

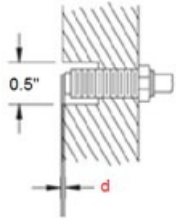

The following data shows how the Metrix TightView System behaves against a competitor's narrow side view system with a counter bore of 0.5 inches (12 mm) and an installation variance of  $\pm 10$  mils (250  $\mu\text{m}$ ).

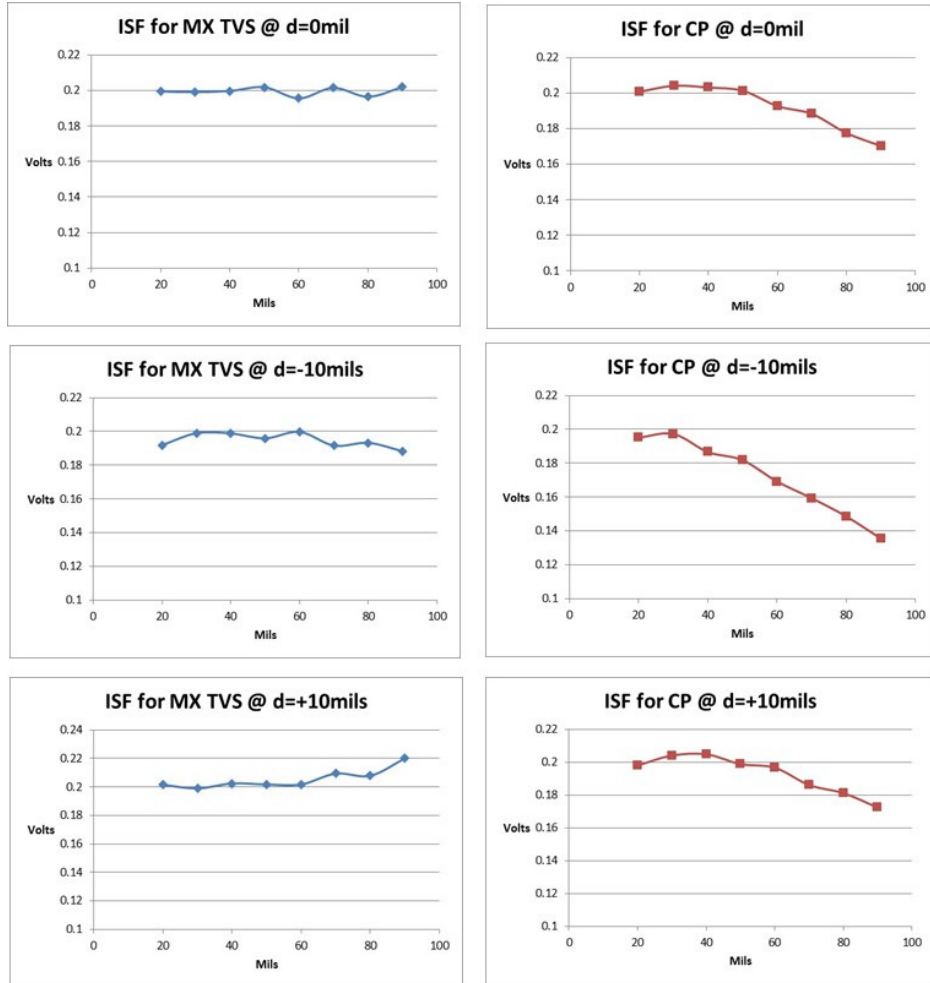

This paper shows that the Metrix TightView™ Proximity Probe System outperforms the competition and meets API 670 specifications. The TightView System is available with the MX8030 5mm or 8mm Proximity Probe, associated Extension Cable, and with the MX2033 Driver and MX2034 Transmitter. See the Digital Proximity System Datasheet for the MX2033 Driver and MX2034 Transmitter, use option BB (09) to order.

<http://www.metrixvibration.com/products/proximity/digital-proximity-system>