

Seismic Velocity 4-20mA Transmitter ST5484E Vibration Transmitter ST5491E

SAFETY MANUAL

TABLE OF CONTENTS

| | | |
|------|--|----|
| 1. | PURPOSE..... | 3 |
| 1.1. | DISCLAIMER AND WARNING | 3 |
| 2. | SYMBOLS USED IN THIS MANUAL..... | 3 |
| 3. | REQUIRED SKILLS AND QUALIFICATIONS..... | 4 |
| 4. | TERMS, DEFINITIONS AND ABBREVIATIONS..... | 5 |
| 4.1. | TERMS AND DEFINITIONS..... | 5 |
| 4.2. | ACRONYMS AND ABBREVIATIONS..... | 7 |
| 5. | REFERENCE DOCUMENTS AND STANDARDS | 8 |
| 6. | PRODUCTS INTRODUCTION..... | 9 |
| 6.1. | PRODUCTS FAMILY IDENTIFICATION | 11 |
| 6.2. | SPECIFICATIONS..... | 15 |
| 7. | RELIABILITY AND SAFETY CHARACTERISTICS | 17 |
| 7.1. | TYPICAL PLACEMENT | 18 |
| 7.2. | RELIABILITY AND SAFETY | 19 |
| 7.3. | SYSTEMATIC CAPABILITY | 20 |
| 7.4. | RANDOM SAFETY INTEGRITY | 20 |
| 7.5. | HARDWARE SAFETY INTEGRITY | 21 |
| 8. | REQUIREMENTS FOR IMPLEMENTATION INTO A SIS | 22 |
| 8.1. | CONNECTION TO LOGIC SOLVER AND CALIBRATION | 22 |
| 9. | PROOF TEST | 24 |

1. PURPOSE

The purpose of this safety manual is to document all the information specifically related to the safety aspect of the Metrix Seismic Transmitters ST5484E and ST5491E. These devices are certified for use as components in a functional safety system. This safety manual is then required in order to enable the integration of the devices into a safety related system with the objective to be in compliance with the requirements of the IEC 61508-2 Annex D.

The information contained in this Safety Manual are valid for the models indicated in paragraph 6.

When the Seismic Transmitter is included in a Safety Instrumented Function, the integrator shall evaluate the performance of the device into the SIF loop, in order to ensure its proper implementation.

The instructions and information contained in this manual are valid only for the Seismic Transmitter, in case of integration in a Safety Instrumented System, the Logic Solver and Final Element information will be provided by the specifics safety manuals.

1.1. DISCLAIMER AND WARNING

By using this product, you hereby signify that you have read this disclaimer and warning carefully and that you understand and agree to abide by the terms and conditions herein. Integrating this device into a safety instrumented system, you agree that you are solely responsible for your own conduct while using this product, and for any consequences thereof. You agree to use this product only for purposes that are proper and in accordance with all applicable laws, rules, and regulations, and all terms, safety prescriptions and precautions, practices, policies and all additional revisions or guidelines that METRIX has made and may make available.

2. SYMBOLS USED IN THIS MANUAL

This manual contains some symbols that are used to focus the user's attention on safety-related aspects. The following symbols are used:



WARNING!

This symbol identifies instructions that must be respected in order to avoid damages to things or to the personnel involved during the use of the SIS.



CAUTION

This symbol identifies instructions that must be followed to avoid malfunctioning of the SIS.



IMPORTANT

This symbol identifies important information that are necessary to understand the meaning of an operation or an activity.



WARNING!

Read the safety manual to become familiar with the features of this product before operating. Failure to operate the product correctly can result in damage to the product, personal property, and cause serious injury. This is a sophisticated safety-related product. It must be operated with caution and common sense and requires some basic mechanical ability. Failure to operate this product in a safe and responsible manner could result in injury or damage to the product, compromise the overall safety of the equipment under control or other property. This product is not intended for use by not functional safety qualified and properly trained personnel. Do not use with incompatible components or alter this product in any way outside of the documents provided by METRIX Instruments Co.

3. REQUIRED SKILLS AND QUALIFICATIONS

This manual is addressed to qualified personnel authorized for installation, operation and maintenance of Metrix ST5484E and ST5491E Seismic Transmitters. As required by the IEC 61508-1 the appropriateness of competence shall be considered taking into account all relevant factors including safety engineering knowledge appropriate to the technology, knowledge of safety regulatory framework and previous experience.



IMPORTANT

In case of unqualified interventions, or if the advice of this manual is neglected, causing disturbances of safety functions, personal injuries, property or environmental damages may occur for which Metrix Instrument Co. cannot take liability.

4. TERMS, DEFINITIONS AND ABBREVIATIONS

4.1. TERMS AND DEFINITIONS

Architecture

Arrangement of hardware and/or software elements in a system.

Architectural constraint

This reports the maximum SIL achievable based on the SIF's subsystems architecture alone. This is calculated solely on the basis of Type A or Type B device selection, redundancy (hardware fault tolerance), and the safe failure fraction (calculated or conservatively assumed if no data is provided). It does not pertain to Systematic Capability or certification. This is calculated as indicated, using respective IEC 61508 or IEC 61511 tables.

Architectural Type

- Type A equipment or (sub)system: "Non –complex" (sub)system or equipment according 7.4.3.1.2 of IEC 61508-2;
- Type B equipment or (sub)system: "Complex" (sub)system or equipment according 7.4.3.1.3 of IEC 61508-2.

Diagnostic Coverage

Fraction of dangerous failures rates detected by diagnostics. Diagnostics coverage does not include any faults detected by proof tests.

Mean Repair Time

Expected overall repair time

Mean Time to Restoration

Expected time to achieve restoration.

Mode of operation

Way in which a SIF operates which may be either low demand mode, high demand mode or continuous mode:

- Low Demand Mode: mode of operation where the SIF is only performed on demand, in order to transfer the process into a specified safe state, and where the frequency of demands is no greater than one per year;
- High Demand Mode: mode of operation where the SIF, is only performed on demand, in order to transfer the process into a specified safe state, and where the frequency of demands is greater than one per year;
- Continuous Mode: where the mode of operation where the SIF retains the process in a safe state as part of normal operation.

Mo0N

SIS, or part thereof, made up of "N" independent channels, which are so connected, that "M" channels are sufficient to perform the SIF.

Hardware Fault Tolerance

A hardware Fault Tolerance of N means that N+1 is the minimum number of faults that could cause a loss of the safety function. In determining the hardware fault tolerance no account shall be taken of other measures that may control the effects of faults such as diagnostics.

Probability of dangerous Failure on demand PFD

Average probability of dangerous failure on demand.

Probability of dangerous Failure per Hour PFH

Average probability of dangerous failure within 1 h.

Proof Test

Periodic test performed to detect dangerous hidden faults in a SIS so that, if necessary, a repair can restore the system to an “as new” condition or a close as practical to this condition.

Safe Failure Fraction

Property of a safety related element that is defined by the ratio of the average failure rates of safe plus dangerous detected failures and safe plus dangerous failures.

Safety instrumented function (SIF)

Safety Function to be implemented by a safety instrumented system (SIS)

Safety instrumented system (SIS)

Instrument system used to implement one or more SIFs.

Safety Integrity

Ability of the SIS to perform the required SIF as and when required.

Safety Integrity Level (SIL)

Discrete level (one out of four) allocated to the SIF for specifying the safety integrity requirements to be achieved by the SIS.

Safe State

State of process when safety is achieved.

Systematic Capability

Measure (expressed on a scale of SC 1 to SC 4) of the confidence that the systematic safety integrity of a device meets the requirements of the specified SIL, in respect of the specified safety function, when the device is applied in accordance with the instructions specified in the device safety manual.

 λ

Failure rate (per hour) of a channel in a subsystem.

 λ_D

Dangerous failure rate (per hour) of a channel in a subsystem.

 λ_S

Safety failure rate (per hour) of a channel in a subsystem.

 λ_{DU}

Dangerous undetected failure rate (per hour) of a channel in a subsystem.

 λ_{DD}

Dangerous detected failure rate (per hour) of a channel in a subsystem.

functional safety

part of the overall safety relating to the EUC and the EUC control system that depends on the correct functioning of the E/E/PE safety-related systems and other risk reduction measures

safe state

state of the EUC when safety is achieved

4.2. ACRONYMS AND ABBREVIATIONS

| | |
|---------------|---|
| BPCS | Basic Process Control System |
| DC | Diagnostic Coverage |
| E/E/PE | Electrical / Electronic / Programmable Electronic |
| EUC | Equipment Under Control |
| FIT | Failure In Time |
| HFT | Hardware Fault Tolerance |
| IEC | International Electro-Technical Commission |
| MRT | Mean Repair Time |
| MTTR | Mean Time to Restoration |
| PFD | Probability of Failure on Demand |
| PLC | Programmable Logic Controller |
| PTC | Proof Test Coverage |
| SC | Systematic Capability |
| SFF | Safe Failure Fraction |
| SIL | Safety Integrity Level |
| SIS | Safety Instrumented System |

5. REFERENCE DOCUMENTS AND STANDARDS

The following table shows the Standards useful for the Safety Manual realization:

| Doc ID | Standard Code | Standard title |
|--------|---------------------|---|
| [D1]. | IEC 61508-1:2011-02 | Functional safety of electrical/electronic/programmable electronic safety-related systems - Part 1: General requirements |
| [D2]. | IEC 61508-2:2011-02 | Functional safety of electrical/electronic/programmable electronic safety-related systems - Part 2: Requirements for electrical/electronic/programmable electronic safety-related systems |
| [D3]. | IEC 61508-4:2011-02 | Functional safety of electrical/electronic/programmable electronic safety-related systems - Part 4: Definitions and abbreviations |
| [D4]. | IEC 61508-5:2011-02 | Functional safety of electrical/electronic/programmable electronic safety related systems - Part 5: Examples of methods for the determination of safety integrity levels |
| [D5]. | IEC 61508-6:2011-02 | Functional safety of electrical/electronic/programmable electronic safety-related systems - Part 6: Guidelines on the application of IEC 61508-2 and IEC 61508-3 |
| [D6]. | IEC 61508-7:2011-02 | Functional safety of electrical/electronic/programmable electronic safety-related systems - Part 7: Overview of techniques and measures |

The following table shows the documents useful for the Safety Manual realization:

| Doc ID | Project Document Name | Document Code | Version |
|--------|--------------------------|---------------------|---------------------|
| [D7]. | Datasheet | Doc# 1004457 | January 2019-Rev AJ |
| [D8]. | Datasheet | Doc# 1004598 | March 2015-Rev F |
| [D9]. | Installation Manual | Doc# M9162 | March 2019-Rev AA |
| [D10]. | Installation Manual | Doc # M9344 | February 2019-Rev J |
| [D11]. | SIL Certificate | MTXI-5484E-ENS-E01 | - |
| [D12]. | Safety Assessment Report | 22-MTX-5484E-FSA-01 | - |

6. PRODUCTS INTRODUCTION

ST5484E Seismic Velocity 4÷20mA Transmitter

The ST5484E is a self-contained seismic velocity transmitter that incorporates a piezoelectric accelerometer sensing element, signal integrator, RMS peak detector, and a 4÷20mA signal conditioner into a single package. It has no moving parts and is encapsulated in a stainless-steel housing. Each transmitter is calibrated to the sensitivity marked on the label.

It can be mounted directly on a machine case or bearing housing without intervening signal conditioning equipment. The amplitude of the integrated acceleration (velocity) signal is converted to a proportional 4÷20mA signal compatible with industrial process control instrumentation such as PLCs, DCSs, and SCADA systems that can provide trending and/or alarming capabilities for a simplified vibration monitoring strategy.

Different machine preparations are required for the two basic transmitter mounting styles: NPT (National Pipe Thread) and machine thread (UNF and Metric).

Four versions of the device are available: flying leads, 2-pin terminal block, 4-pin terminal block (with the additional feature of signal extraction for waveform generation) and 2-pin MIL connector. ST5484E version is not equipped with local display for indication purposes. The following figures show the different ST5484E versions.



Flying Leads
(Option D=0, 1, 5, or 6) (2-wire shown; 4-wire also available)



2-Pin Terminal Block
(Option D=2)



4-Pin Terminal Block
(Option D=3)



2-Pin MIL Connector
(Option D=4)

ST5491E Vibration Transmitter

The ST5491E vibration transmitter is the suitable solution when continuous, local indication of vibration levels is required at the transmitter. Its sensing and transmitter elements are similar to the ST5484E, but it includes a 2½ digit LCD display in an integral conduit elbow and is rated for use in temperatures from -10°C to +70°C. Model ST5491E is a suitable solution for sensing vibration on most plant equipment. It consists of an indicating velocity vibration sensor and signal conditioner in a single package. A two-wire loop signal proportional to velocity is generated for transfer to a programmable logic controller (PLC), distributed control system (DCS) or other 4÷20mA input devices. The device is mounted on the machine case, connected through the 2-wire loop for vibration recording. Typical applications include low and medium speed machines. The transmitter can be supplied with optional screw cover elbow fittings for connecting flexible conduit. Each transmitter is calibrated to the sensitivity marked on the label.



6.1. PRODUCTS FAMILY IDENTIFICATION

This Safety Manual is valid for each product listed in this paragraph.

ST5484E Seismic Velocity 4÷20mA Transmitter

| Full Scale Range ¹ | | | | |
|-------------------------------|---|--|---|--|
| | 1 | 2 | 1 | 1.0 in/sec (25.4 mm/s) peak ² |
| | 1 | 2 | 2 | 0.5 in/sec (12.7 mm/s) peak ² |
| | 1 | 2 | 3 | 2.0 in/sec (50.8 mm/s) peak ² |
| | 1 | 2 | 4 | 5.0 in/sec (127 mm/s) peak ² |
| | 1 | 2 | 6 | 0.8 in/sec (20.3 mm/s) peak ² |
| | 1 | 3 | 2 | 3.0 in/sec (76.2 mm/s) peak ² |
| | 1 | 5 | 1 | 1.0 in/sec (25.4 mm/s) true RMS |
| | 1 | 5 | 2 | 0.5 in/sec (12.7 mm/s) true RMS |
| | 1 | 5 | 3 | 2.0 in/sec (50.8 mm/s) true RMS |
| | 1 | 5 | 4 | 5.0 in/sec (127 mm/s) true RMS |
| | 1 | 5 | 6 | 0.8 in/sec (20.3 mm/s) true RMS |
| | 1 | 6 | 2 | 3.0 in/sec (76.2 mm/s) true RMS |
| BB | Housing Material & Stud Size ¹ | | | |
| | 00 | 303 SS housing, ¼" NPT stud | | |
| | 01 | 303 SS housing, ½" NPT stud | | |
| | 02 | 303 SS housing, ⅜ x 24 UNF – ½" stud | | |
| | 03 | 303 SS housing, ½ x 20 UNF – ½" stud | | |
| | 04 | 303 SS housing, M8 x 1.0 – 12 stud | | |
| | 05 | 303 SS housing, M10 x 1.25 – 12 stud | | |
| | 06 | 303 SS housing, ¼ x 20 UNC – ½" stud | | |
| | 07 | 303 SS housing, ¼ x 28 UNF – ½" stud | | |
| | 08 | 303 SS housing, M8 x 1.25 – 12 stud | | |
| | 09 | 303 SS housing, ⅜ x 16 UNC – ½" stud | | |
| | 10 | 316 SS housing, ¼" NPT stud | | |
| | 11 | 316 SS housing, ½" NPT stud | | |
| | 12 | 316 SS housing, ⅜ x 24 UNF – ½" stud | | |
| | 13 | 316 SS housing, ½ x 20 UNF – ½" stud | | |
| | 14 | 316 SS housing, M8 x 1.0 – 12 stud | | |
| | 15 | 316 SS housing, M10 x 1.25 – 12 stud | | |
| | 16 | 316 SS housing, ¼ x 20 UNC – ½" stud | | |
| | 17 | 316 SS housing, ¼ x 28 UNF – ½" stud | | |
| | 18 | 316 SS housing, M8 x 1.25 – 12 stud | | |
| | 19 | 316 SS housing, ⅜ x 16 UNC – ½" stud | | |
| | 20 | 303 SS housing, ½ x 13 UNC – ½" stud | | |
| | 30 | 316 SS housing, ½ x 13 UNC – ½" stud | | |
| C | Hazardous Area Certification ^{3,4,5} | | | |
| | 0 | No Hazardous Approval Area | | |
| | 1 | CSA US/C, Class I, Div 2, Grps A-D (non-incendive) | | |

| | | |
|----------|---|--|
| | 2 | CSA US/C, Class I, Div 1, Grps B-D and Class II, Div 1, Grps E-G (explosion proof, includes a 8200 conduit |
| | 3 | ATEX, Ex ia IIC T4 Ga (intrinsically safe) |
| | 4 | CSA US/C, Class I, Div 1, Grps A-D (intrinsically safe) |
| | 5 | INMETRO, Ex ia IIC T4 Ga (intrinsically safe) |
| | 6 | INMETRO, Ex d IIC T4 Gb (explosion proof, includes 8200 conduit elbow) |
| | 7 | IECEX/KOSHA Ex ia IIC T4 Ga (intrinsically safe) 16-AV4BO-0214X |
| | 8 | ATEX/IECEX/KOSHA Ex d IIC T4 Gb (explosion proof, includes 8200 conduit elbow) 16-AV4BO- 0213X |
| | A | EAC, Ex ia IIC T4 Ga (intrinsically safe), Ex d IIC T4 Gb (explosion proof, includes 8200 conduit elbow) |
| | B | ATEX/EAC, Ex ia IIC T4 Ga (intrinsically safe) |
| D | | Connection Type³ |
| | 0 | 24" Flying Leads, 2-wire ⁵ ; (4-20 mA output only) |
| | 1 | 24" Flying Leads, 4-wire ⁵ ; (4-20 mA output and dynamic raw acceleration signal) |
| | 2 | Terminal Block, 2-wire ⁵ ; (4-20 mA output only) |
| | 3 | Terminal Block, 4-wire ⁵ ; (4-20 mA output and dynamic raw acceleration signal) |
| | 4 | 2-Pin MIL-Style (MIL-C-5015); (4-20 mA output only) |
| | 5 | 72" Flying Leads, 2-wire ⁵ ; (4-20 mA output only) |
| | 6 | 72" Flying Leads, 4-wire ⁵ ; (4-20 mA output and dynamic raw acceleration signal) |
| E | | High-Pass Filter |
| | 0 | 2 Hz (standard) |
| | 1 | 5 Hz |
| | 2 | 10 Hz |
| | 3 | 20 Hz |
| | 4 | 50 Hz |
| | 5 | 100 Hz |
| | 6 | 200 Hz ⁶ |
| | X | Custom (consult factory) ⁶ |
| F | | Low-Pass Filter |
| | 0 | 1500 Hz (standard) |
| | 1 | 500 Hz |
| | 2 | 1000 Hz |
| | 3 | 2000 Hz |
| | 4 | 250 Hz ⁶ |
| | 5 | 230 Hz ⁶ |
| | 6 | 350 Hz ⁶ |
| | 7 | 450Hz |
| | X | Custom (consult factory) ⁶ |

NOTES:

1. Smaller diameter mounting studs are not able to withstand Sustained ambient vibration levels above 2.0 in/sec. Consult Table 1 for allowable combinations of A and B options.
2. The ST5484E uses an RMS amplitude detection circuit. Full scale ranges in peak units use scaled RMS (i.e., RMS x $\sqrt{2}$). The "derived peak" measurements will equal true peak only under

the special case of a pure sinusoid, not complex vibration signals.

3. Hazardous Area Certifications are not compatible with all connection types. Consult Table 2 for allowable combinations of C & D options.
4. Some approvals require intrinsic safety barriers, others require Explosion-Proof wiring practices. Refers to datasheets.

5. Refer to the Accessories section of the datasheets. Units sold with an explosion proof rating will include an 8200-000 IEC or 8200-000 explosion proof elbow that will be affixed at the factory.

6. High- and Low-Pass filter corners for standard filters must be

separated by at least one octave (low-pass frequency must be at least twice the high-pass frequency). All combinations are allowed except E = 6 and F = 4, 5, or 6. Custom filters with closer separation and/or different roll-offs may be available in some instances. Consult the factory if custom filters are required.

| Table 2: Allowable Combinations for AAA & BB Options | |
|--|--|
| Full Scale Range AAA= | Allowable BB options (Mounting Stud Sizes) |
| 121, 122, 123, 126, 151, 152, 153, 156 | All (no restrictions) |
| 124 and 154 | 00, 01, 03, 10, 11, 13 |
| 132 and 162 | 00, 01, 02, 03, 05, 09, 10, 11, 13, 15, 19 |

| Table 1: Allowable Combinations for C & D Options | | | | | | | | | | | |
|---|---|---|---|---|---|---|---|---|---|---|---|
| D\C | 0 | 1 | 2 | 3 | 4 | 5 | 6 | 7 | 8 | A | B |
| 0 | Y | Y | Y | Y | Y | Y | Y | Y | Y | Y | Y |
| 1 | Y | Y | Y | Y | Y | Y | Y | Y | Y | Y | Y |
| 2 | Y | Y | Y | Y | Y | Y | Y | Y | Y | Y | Y |
| 3 | Y | Y | Y | Y | Y | Y | Y | Y | Y | Y | Y |
| 4 | Y | Y | N | Y | Y | Y | N | Y | N | N | Y |
| 5 | Y | Y | Y | Y | Y | Y | Y | Y | Y | Y | Y |
| 6 | Y | Y | Y | Y | Y | Y | Y | Y | Y | Y | Y |

ST5491E Vibration Transmitter

| ST5491E - A - B - C D - E F | | | |
|-----------------------------|--|---------------------------------------|--------------------------------|
| □□□-□□-□□-□□ | | | |
| A | Full Scale Range | | |
| 0 | 2 | 1 | 1.0 in/s (25.4 mm/s), pk |
| 0 | 2 | 2 | 20 mm/s (0.787 in/s), pk |
| 0 | 2 | 3 | 100 mm/s (3.94 in/s), pk |
| 0 | 2 | 4 | 2.0 in/s (50.8 mm/s), pk |
| 0 | 5 | 1 | 1.0 in/s (25.4 mm/s), true RMS |
| 0 | 5 | 2 | 20 mm/s (0.787 in/s), true RMS |
| 0 | 5 | 3 | 100 mm/s (3.94 in/s), true RMS |
| 0 | 5 | 4 | 2.0 in/s (50.8 mm/s), true RMS |
| B | Mounting Stud/ Housing Material | | |
| 0 | 0 | Integral ¼" NPT stud mount, 303 SST | |
| 0 | 1 | Integral ½" NPT stud mount, 303 SST | |
| 0 | 2 | 3/8 - 24 UNF - ½" stud mount, 303 SST | |
| 0 | 3 | 1/2 X 20 UNF - ½" stud mount, 303 SST | |
| 0 | 4 | M8 X 1-12 stud mount, 303 SST | |
| 0 | 5 | M10 X 1.25-12 stud mount, 303 SST | |
| 1 | 0 | Integral ¼" NPT stoud mount, 316 SST | |
| 1 | 1 | Integral ½" NPT stud mount, 316 SST | |
| 1 | 2 | 3/8 - 24 UNF X ½" stud mount, 316 SST | |
| 1 | 3 | 1/2 X 20 UNF - ½" stud mount, 316 SST | |
| 1 | 4 | M8 X 1-12 stud mount, 316 SST | |
| 1 | 5 | M10 X 1.25-12 stud mount, 316 SST | |
| C | Hazardous Area Certifications | | |
| 1 | CSA/NRTL/C Class I, Div 2, Grps C & D | | |
| 2 | CSA/NRTL/C Class I, Div 1, Grps C-D & Class II, Div 1, Grps E-G (available with flying leads ONLY) | | |
| D | Connection | | |
| 0 | 4-20 mA: Flying leads | | |
| E | High Pass Filter | | |
| 0 | No filter (2 Hz), Standard | | |
| 1 | 5 Hz | | |
| 2 | 10 Hz | | |
| 3 | 20 Hz | | |
| 4 | 50 Hz | | |
| 5 | 100 Hz | | |
| 6 | 200 Hz | | |
| F | Low Pass Filter | | |
| 0 | No filter (1500 Hz), Standard | | |
| 1 | 500 Hz | | |
| 2 | 1000 Hz | | |
| 3 | 2000 Hz | | |

6.2. SPECIFICATIONS

ST5484E Seismic Velocity 4÷20mA Transmitter

| INPUTS | |
|--|---|
| Supply voltage | 11 – 29.6 VDC (24 VDC nominal) (intrinsically safe); 11 – 30 VDC (24 VDC nominal) (explosion proof and non-incendive); Metrix patented IPT® independent polarity diode bridge circuit allows voltage to be connected without regard to polarity |
| Circuit-to Case Isolation | 500 Vrms |
| OUTPUTS | |
| 4÷20mA | Proportional to velocity full scale range (4mA = 0 vibration, 20mA = full scale vibration) |
| Maximum 4÷20mA loop resistance | $RL = 50 \times (Vs - 11) \Omega$ where Vs = Supply Voltage at transmitter terminals. NOTE: For every 50 Ω of resistance in the 4-20 mA loop, 1 VDC above the minimum supply voltage (11 VDC) must be available at the transmitter terminals. For example, 12 VDC at the transmitter terminals will allow a 50 Ω loop resistance; 30 VDC at the transmitter terminals will allow a 950 Ω loop resistance. For intrinsically safe applications, the use of a passive zener barrier will incur a voltage drop of approximately 8.1 volts at the barrier, and the loop supply voltage is limited to 26 VDC. Thus, with passive barriers and a 26 VDC supply, the maximum available voltage at the transmitter will be 17.9 VDC and the corresponding maximum loop resistance will be 345 Ω . |
| Dynamic signal | 100 mV/g (10.2 mV / m/s ²) acceleration, filtered to same frequency band as proportional velocity |
| Dynamic signal output impedance | 10 k Ω |
| Recommended minimum load impedance (Zload) for dynamic signal connection | 500 k Ω |
| SIGNAL PROCESSING | |
| Frequency Response (+/- 3dB passband) | 2 Hz – 1500 Hz (standard) 2 Hz – 2000 Hz (optional) |
| Optional High-Pass Filter Corner | 5, 10, 20, 50, 100, or 200 Hz |
| High-Pass Roll-Off | 12 dB / octave |
| Optional Low-Pass Filter Corner | 230, 250, 350, 450, 500, or 1000 Hz |
| Low-pass Roll-Off | 12 dB / octave |
| Accuracy | ± 2.5% (within passband) ± 4% (at corner frequencies) |
| Maximum Full Scale | 5.0 in / sec (others by request) |
| Minimum Full Scale | 0.5 in / sec (others by request) |
| Full Scale Range Units | <ul style="list-style-type: none"> in / sec (standard) mm / sec (available by request) |
| Amplitude Detection | True RMS detector; full scale may be ordered with True RMS units or scaled RMS (RMS x $\sqrt{2}$) for “derived peak” measurements |

| PHYSICAL | |
|-----------------------|--|
| Operating Temperature | -40°C to +100°C (-40°F to +212°F) |
| Sensitive Axis | Same as mounting stud axis |
| Axis Orientation | Any |
| Enclosure Material | <ul style="list-style-type: none"> • 303 stainless steel (standard) • 316 stainless steel (optional) |
| Enclosure Rating | <p><u>MIL-Style Connector:</u></p> <ul style="list-style-type: none"> • IP67 and NEMA 4X <p><u>Flying Leads and Terminal Block Connectors:</u></p> <ul style="list-style-type: none"> • IP66 when used with the following conduit elbows: 8200-001-IEC, 8200-003-IEC, 8200-008-IEC, • No Rating when used with the following conduit elbows: 8200-001, 8200-003, 8200-005, 8200-008, 8200-101, 8200-103, 8200-108 |
| Connector Types | <ul style="list-style-type: none"> • Flying Leads (2- and 4-wire) • MIL-C-5015 (2-wire only) • Terminal Block (2- and 4-wire) |
| Humidity | <ul style="list-style-type: none"> • 95%, non-condensing (flying lead and terminal block versions) • 100% condensing (MIL-style connector) |

ST5491E Vibration Transmitter

| SPECIFICATIONS | |
|------------------------------|---|
| Vibration Range | 4 - 20 mA output proportional to velocity |
| Accuracy | 2% |
| Indicator | 2½ digits, ips or mm/s |
| Frequency Response | Standard: 2 - 1500 Hz, available up to 2000 Hz; 12 dB / oct high pass and low pass filters are used |
| Axis Orientation | Any |
| Supply Voltage (Vs) | 13 to 30 VDC |
| Isolation | 500 Vrms, circuit to case |
| Electrical Connection | Flying leads - 457 mm (24 in.) length, 18 AWG |
| Maximum Load Resistance (RL) | 50 (Vsupply - 13) Ω |
| Service Temp. Rating | -10°C to +70°C (+14°F to +156°F) |
| Enclosure Materials | 303 SS / 316SS |



IMPORTANT

The information listed in the above table are extracted by datasheet [D7]-[D8] and shall be considered for reference only. In case of mismatch, the datasheet have the priority on the present table.

7. RELIABILITY AND SAFETY CHARACTERISTICS

| | |
|-------------------------|--|
| Safety Functions | Provides a 4-20mA DC signal output proportional to the vibration amplitude of rotating equipment portion where installed. |
| Installation | Refer to [D9]-[D10]. |
| Lifetime | When using in the prescribed manner indicated in [D9]-[D10], the device can operate in safety applications up to 20 years. |
| Diagnostic | No internal diagnostics are present. |
| Interface | ST5484E transmitters could require intrinsically safe barriers as interfaces toward the SIS, depending on the installation area. Refer to [D9] for further details about recommended IS barrier. |



WARNING!

Modification to the hardware are not permitted. Do not use other connectors than the ones listed in [D7]-[D8].



WARNING!

To avoid potential hazards, use this product only as specified. Only qualified personnel should perform installation, uninstallation and wiring procedures. If you suspect there is damage to this product, have it inspected by qualified personnel.



WARNING!

Interface devices such as intrinsically safe barriers could modify the SIS safety. The end-user shall take into account this possibility during calculation of the whole safety loop implementing the SIF.



WARNING

Do not touch exposed electrical connections and components when power is present.

7.1. TYPICAL PLACEMENT

The ST5484E measures seismic vibration (i.e. vibration velocity) at the attachment point on the machine, using engineering units of in/s (inches per second) or mm/s (millimeters per second) depending on the selected ordering option. The transmitter's sensitive direction is through the long axis of its cylindrical body. It will not measure side-to-side motion. Typical transmitter mounting for casing vibration measurement is in the horizontal direction at the bearing housing as shown in the following figure.

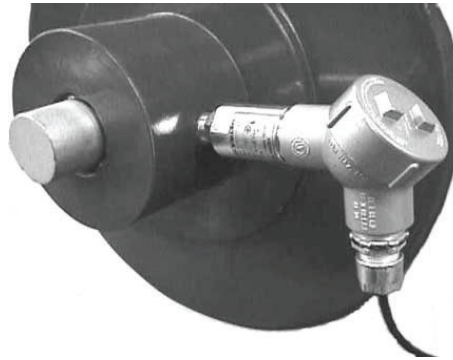

CAUTION

Do not use a pipe wrench when installing the seismic transmitter. A pipe wrench can apply extreme forces to the body and potentially damage electronic components.

7.2. RELIABILITY AND SAFETY

The reliability parameters have been obtained considering the Mechanical Vibration Switch as element of a safety-related system with the safety function: (s)

Provides a 4-20mA DC signal output proportional to the vibration amplitude of rotating equipment portion where installed.



IMPORTANT

The design of each Safety Instrumented Function shall meet the requirements listed in the reference standards that shall be selected by taking into account the specific application.

Seismic transmitters are appropriate for applications where a stand-alone monitoring system is not warranted. The ST5484E handles general-purpose vibration measurements on a wide range of rotating and reciprocating machinery with rotating speeds between 120- and 6000-rpm. Seismic measurements are suitable for machines with rolling-element bearings because shaft vibration in such machines is usually transmitted directly through the bearing to the bearing housing without substantial damping or attenuation. Seismic transducers can also measure vibration that does not originate at the shaft, such as bearing-related wear and defects, footing/foundation problems, piping resonances that are coupled to the machine, etc. When the machine under control reaches the dangerous vibrations threshold, the SIS intervention must result in the machine trip.

ST5491E is typically applied in blowers, centrifuges, compressors, engines, fans, generators, motors, pumps, turbines, turbocharges.



IMPORTANT

For machines with rolling element bearings and running above 6000 rpm, and/or where impulsive casing vibration occurs, acceleration may be a better measurement.

Specific activities necessary to investigate and reach a judgment on the adequacy of the functional safety achieved by the E/E/PE safety-related system or compliant items (elements/subsystems) has been conducted by an independent assessor. The following tables show the safety parameters of the devices listed in paragraph 6.1. For a detailed explanation of the parameters meaning, application and associated assumptions refer to paragraphs 7.3-7.5.

Table 1 Reliability parameters for Seismic Transmitters ST5484E and ST5491E (all configurations).

| Configuration | λ_{SU} | λ_{SD} | λ_{DU} | λ_{DD} | λ_{RES} |
|----------------------------|---------------------------|----------------|----------------------|----------------|-----------------|
| All configurations | 94 | 0 | 117 | 114 | 640 |
| Systematic Capability (SC) | 2 (Route 1 _s) | | | | |
| Hardware Safety Integrity | Type A | | Route 1 _H | | |

7.3. SYSTEMATIC CAPABILITY

Techniques and measures to control and avoid systematic failures during the different phases of the lifecycle have been evaluated and found to be sufficient to meet the requirements of SIL 2 in accordance to IEC 61508, Parts 1 - 7:2010. The compliance with the requirements has been achieved following the compliance Route 1_s.

The systematic capability provides a quantitative estimation of the robustness of the device against systematic failures resulting from design, project management and documentation quality. An appropriate group of techniques and measures to prevent the introduction of faults during the design and development phases are in place.

To control systematic faults the maintenance and test requirements formalized at design stage must be followed.

In order to preserve the systematic capability, the Seismic Transmitters ST5484E and ST5491E must be used following the constraints reported in this manual in term of authorized personnel, installation, operating conditions and maintenance.



WARNING!

The declared systematic capability level is valid only if the requirements and limitations reported in this Safety Manual are fulfilled

7.4. RANDOM SAFETY INTEGRITY

The failure rates show in the previous tables are resulting from the FMEDA analysis, a FMEA extension that combines standard FMEA techniques with extension to identify online diagnostics techniques and the failure modes relevant to safety instrumented system design. The failure rates shall be used for the PFD_{AVG} estimation, taking into consideration all parameters such as redundancy, architectural constraints, diagnostic capability, also introduced by the whole system, including the considerations about the proof test and its effectiveness, mean time of restoration, up to the maintenance capability and its minimum characteristics.

The assumptions associated with these failure rates are as follows:

- Failure rates are constant, wear-out or infant mortality contributions are not included;
- The tabulated failure rates are in Failures in Time (FIT):

$$1 \text{ FIT} = [10^{-9} \text{ h}^{-1}]$$

The device total failure rate λ is given by $\lambda = \lambda_{SU} + \lambda_{SD} + \lambda_{DU} + \lambda_{DD} + \lambda_{RES}$.

The dangerous undetected failure rate λ_{DU} is due to faults that cause the failure of the safety function, as the seismic transmitter output signal is no more reliable, and the machine is not tripped even if the dangerous vibration threshold is reached. The high vibration level is then not detected and the EUC could be seriously damaged. The two main phenomena leading to undetected failures are drift and non-linearity. The former cause the addition of unwanted signals to the current exit (white noise or communication interference) that modify the output signal while maintaining it in specs; this renders diagnostic methods ineffective. When linearity loss occurs, the 4-20 mA transmitter output is no more linearly related to the vibration level (in/s or mm/s), so the logic solver is unable to correctly convert the current signal to the corresponding vibration value, as the logic has been calibrated using a linear calibration curve.

The dangerous detected failure rate λ_{DD} value is due to seismic transmitter faults (i.e. short circuit, open circuit and faults causing signal under-range and over-range) leading to the output current signal to exit the normal operating range 4-20mA. As the transmitters do not have internal diagnostics capabilities, the SIS logic solver shall be able to detect these seismic transmitter faults through its current output signal.



IMPORTANT

If the logic solver is not able to detect the output current signal over-range and under-range, λ_{DU} value is given by $\lambda_{DU} + \lambda_{DD}$ as no diagnostic measure is implemented.

The safe failure rate $\lambda_s = \lambda_{SU} + \lambda_{SD}$ represents failure of elements or subsystems that play a part in implementing the safety function, as they result in the spurious operation of the safety function or in the increase of the probability of spurious operation of the safety function to put the EUC (or part thereof) into a safe state or maintain a safe state;

The residual failure rate λ_{RES} includes the NO PART and NO EFFECT failure rates that is failure of a component that plays no part in implementing the safety function (NO PART) and failure of an element that plays a part in implementing the safety function but has no direct effect on the safety function (NO EFFECT).

The integration in the SIS, the whole SIS validation, and the PFD_{avg} calculation of the whole safety loop implementing the SIF is under end-user responsibility, together with the verification of the compliance with the allocated target SIL.

7.5. HARDWARE SAFETY INTEGRITY

The constraints on hardware safety integrity have been verified in order to achieve a sufficiently robust architecture taking into account the level of element and subsystem complexity following the compliance route 1H.

Route 1H is based on hardware fault tolerance and safe failure fraction concepts. According to Route 1H, in order to determine the maximum safety integrity level that can be claimed, the safe failure fraction shall be calculated for the item under analysis using the failure rate data.

The maximum allowable safety integrity level that can be claimed in terms of architectural constraints can be determined according to tables 2 and 3 (7.4.4.2 IEC 61508-2). Different tables are used if the element is classified as type A or B.

Seismic Transmitters ST5484E and ST5491E have been classified as **type A** elements, following 7.4.4.1.2. IEC 61508-2 explanation.

An element can be regarded as type A if, for the components required to achieve the safety function:

- a) The failure modes of all constituent components are well defined; and
- b) The behavior of the component under fault conditions cannot be completely determined; or
- c) There is sufficient dependable failure data to show that the claimed rates of failure for detected and undetected dangerous failures are met.

8. REQUIREMENTS FOR IMPLEMENTATION INTO A SIS

Seismic transmitter shall be connected to a logic device that reads the sensor 4-20mA output signal and trip the machine if the vibration dangerous threshold is reached.

The Logic solver shall also be able to recognize the transmitter fault through its signal and shall be programmed to recognize and communicate signal under and over range and consequently to trip the machine.



WARNING!

Machine under control must be tripped if the transmitter output signal is out of the 4-20mA normal operating range.

8.1. CONNECTION TO LOGIC SOLVER AND CALIBRATION

The first step for PLC (or other logic solver element) is to determine the source of power. The ST5484E requires loop power. Some analog input channels on a PLC or DCS, for example, provide this power from within. If they do not provide power, an external power supply must be provided.

The following figure schematizes an example of the typical wiring for single-transmitter loops applications:

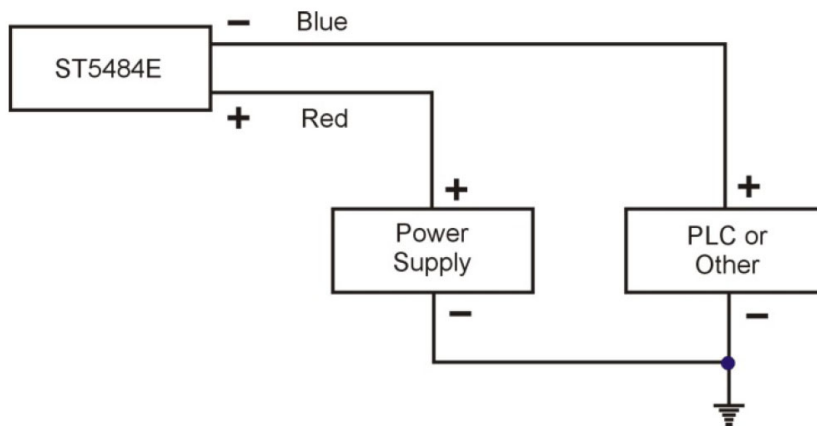

The logic solver must be correctly calibrated before installation, using a linear calibration curve that allows to associate the analogic 4-20mA signal values to the corresponding vibration ones (in/s or mm/s).

The vibration dangerous threshold shall also be setted.

The example below is based on a standard 1.0 in/s transmitter.

| When vibration level at transmitter | Transmitter output | Logic Solver reading |
|-------------------------------------|--------------------|----------------------|
| 0 in/s (no vibration) | 4 mA | 0 in/s |
| 1 in/s (full scale vibration) | 20 mA | 1 in/s |

Momentary “jolts” that can occur at start-up, or during some operating condition changes, do not reflect a machine’s steady-state operating condition. To prevent such occurrences from generating nuisance alarms, program a time delay into the alarm such that the indicated vibration level must persist above the alarm setpoint for a preset period of time before an alarm is generated. The indicated vibration level must cross the threshold level and stay above it for a preset time before any alarm action is taken.



CAUTION

The sensor isn't designed to impulsive vibration. It shall be used in application having a natural vibration frequency in the range of the sensor in order to allow a proper diagnostic of the correct functionality of the sensor.



CAUTION

The device must be rigidly attached to the machine so that it reflects machinery vibration, not vibration incurred by a loose mounting, an insufficiently stiff mounting bracket, or a bracket resonance.

9. PROOF TEST

The maximum proof test interval has been defined as 5 years. Seismic Transmitters ST5484E and ST5491E shall be tested to verify that the correct functioning has not been compromised by the continuous exposition to vibration.



IMPORTANT

The proof test interval shall be chosen taking into consideration the main characteristics of each safety function where the seismic transmitter is involved. This selection it's under the sole responsibility of who is in charge to implement the ST5484E or ST5491E into the SIS and shall not exceed the 5 years.

Description of the test

This test is executed in order to verify the device correct response.

The seismic transmitter is mounted on a shaker and exposed to vibrations with different amplitude at the fixed frequency of 100Hz. For every amplitude value, the corresponding transmitter output current value shall be compared with the values reported in the table below. This test allows to verify if the signal current output belongs to the normal operating range 4-20mA and the linearity of said signal.

Test Instrument and equipment

- Shaker
- Power supply
- Digital multimeter

Test procedure

- Unscrew the seismic transmitter from its mounting location
- screw in the seismic transmitter into the appropriate adapter on the shaker
- connect the transmitter to the power supply and the digital multimeter, as shown in the following figures

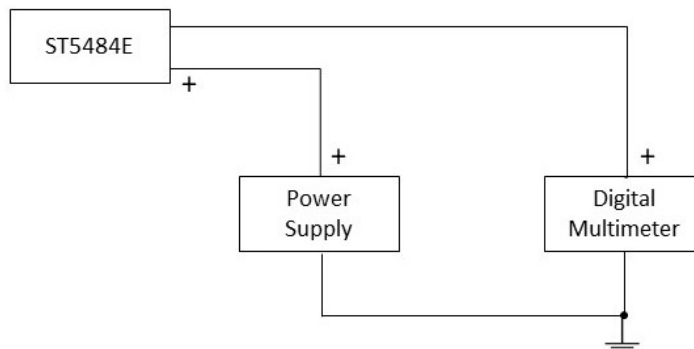

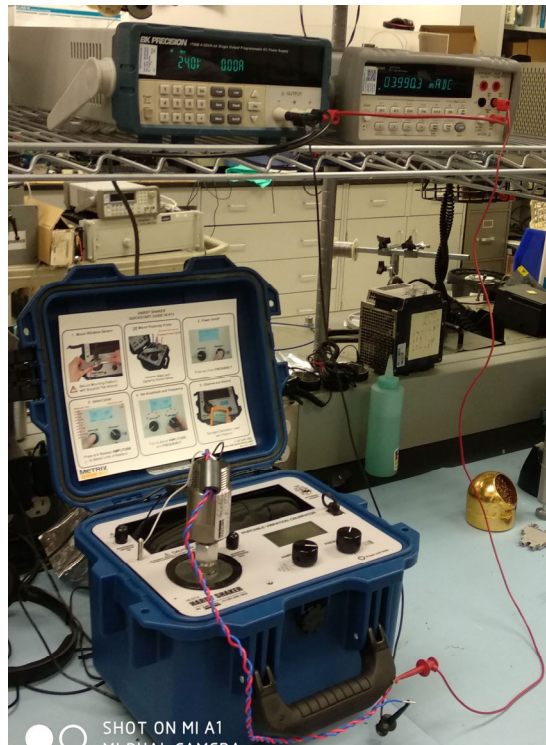

- Acquire the velocity probe output maintaining the frequency constantly at 100Hz and changing the vibration amplitude from 0 to 1 (% of the full-scale range)



| Amplitude | Output |
|-----------|----------|
| 0 | 4.001mA |
| 0.20 | 7.293mA |
| 0.30 | 8.946mA |
| 0.40 | 10.607mA |
| 0.50 | 12.253mA |
| 0.60 | 13.902mA |
| 0.80 | 17.150mA |
| 1 | 20.393mA |

NOTE

- 1) Output values in case of 24Vdc power supply, frequency = 100Hz and varying amplitude
- 2) When comparing the output values consider a 5% tolerance

Test results

The result of the test can be considered positive if the transmitter output for the different amplitude inputs correspond to the values reported in the table (consider a 5% tolerance). If the test is successfully completed, remount the seismic transmitter on the machine under control, following the instruction given in [D9]-[D10].

If there is no value correspondence the test is not passed, and the seismic transmitter must be replaced with a correct functioning one.

Following the above procedure, the proof test coverage is 98%.

**WARNING!**

Even if the proof test has been properly carried out, wrong or inappropriate maintenance may compromise the switch. Follow the instruction listed into the user manual is mandatory to ensure the correct operability this equipment and consequently of the whole SIS.