

OVERVIEW

The 5580 Smart Signal Conditioner and the SW5580 Dual Channel Configurable Switch are basically the same product, the difference is the SW5580 has options for relay contacts. The 5580 and SW5580 are a next generation DIN rail mounted Smart Vibration Signal Conditioner and Switch that comes in a single channel or dual channel enabled configuration. They have been designed to accept signals from machine casing mounted velocity sensors, accelerometers or shaft observing proximity probe systems and produce a 4-20 mA output proportional to the measured variable as well as the raw signal. It provides the user with a configurable signal input type for one or two independent channels. For each channel, a green LED indicates sensor and cable integrity. In the event of sensor failure, the LED changes to red and the output current is driven below 3.6 mA, thereby signaling a malfunction. The alarm status is indicated by the LED flashing yellow for Alert and flashing red for Danger. A BNC connector gives access to the raw input signal prior to any filtering for local analysis. A built-in 4-line alpha-numeric LCD display is used to display both dynamic input and 4-20 mA output signals. Isolation is provided between input, outputs and supply. In the SW5580 version each channel comes with two optional relays, either solid state or dry contacts, that can be configured for alarm level and time delay.

Designed for ease of use, the mini-USB interface is fitted for quick and easy configuration. Just connect a standard USB to mini-USB cable (maximum 5 meter) between the 5580 or SW5580 and your PC. Using our free configuration software, you can configure the device in the field to meet your application requirements. Use as a single or optional dual channel device. The second channel can be enabled in the field for a fee. Dual Path (i.e. single sensor with two signal conditioning outputs) or Dual Channel (i.e. two sensors with one signal conditioning output each) modes are allowed.

FEATURES

- Two channel module, one or two channels enabled
- Field configurable full-scale range, input type and High, Low and Band Pass Filters
- Reduced cost alternative to rack mounted monitors
- Provides sensor excitation
- Drives dynamic signals over long distances (300 m or 1000 ft)
- Interfaces an accelerometer, velocity sensor, or proximity probe system to a PLC, DCS or other 4-20 mA input monitor



FEATURES CONTINUED

- Provides 4-20 mA proportional output and is compliant with the NAMUR standard
- Alpha-numeric LCD display for both dynamic input and 4-20 mA output signals
- Dual Path or Dual Channel modes are allowed
- LED for Ok/Not Ok and alarm levels
- BNC connector for waveform analyzers
- For the SW5580 optional solid state or dry contact relays are available
- Relays are set at 25% and 50% of the full scale range and associated time delays are set at 3 seconds

APPLICATIONS

- Centrifugal Compressors
- Motors & Generators
- Process Pumps
- Centrifuges
- Natural Gas/Diesel Engines
- Gas Turbines
- Other Rotating/Reciprocating Machines

SOFTWARE

- Change configuration software is only required if you want to change the as ordered configuration.
- Download free configuration software from Metrix website.

TYPICAL INSTALLATION DIAGRAM

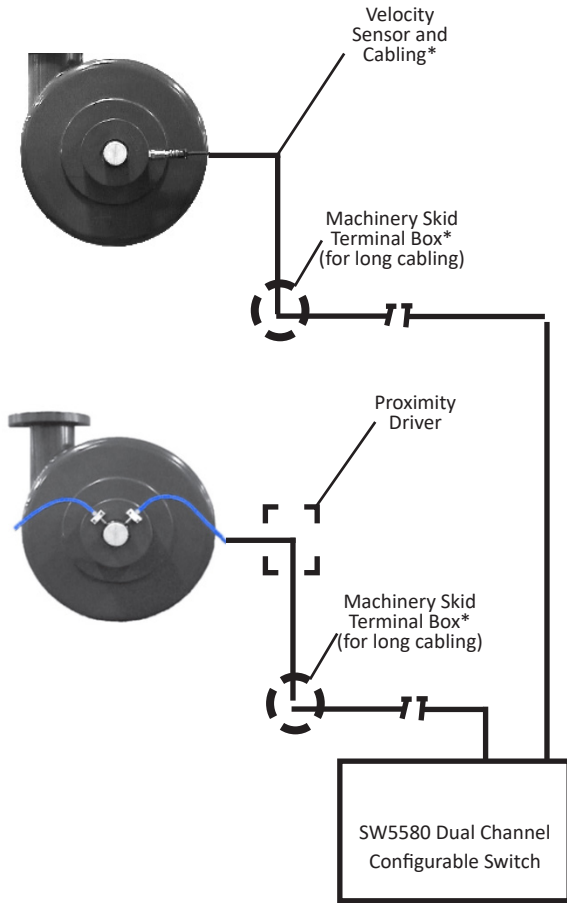

SPECIFICATIONS

Input signal	100 to 500 mV/ips, 10 to 100 mV/g, 100-200 mV/mil
Sensor Excitation Provided	Required only for piezo-velocity sensor input types: 24 VDC, 4 mA constant current standard.
Output Accuracy	4-20 mA dc (source) \pm 5% bounded by the NAMUR standard
Dynamic Signal Output	Buffered input signal at BNC (5m or 16ft) and terminal block (300m or 1000ft)
Scale Range	See "Ordering Option CCCC"
Maximum Load Resistance	600 Ω
Frequency Response	2 Hz to 2 kHz for velocity 2 Hz to 5 kHz for proximity 2 Hz to 10 kHz for acceleration
Sensor Malfunction	Output current driven below 3.6 mA and sensor status green LED turns to red when sensor/cable not OK
Filters	Optional low-pass and high-pass filters (36 db/octave). Filter section does not affect dynamic signal. See "Ordering Option D & E"
Vibration Indicator	4-digit LCD display of vibration level
Temperature Limits	5580: -40° C to +85° C (-40° F to +185° F) SW5580: -40° C to +65° C (-40° F to +149° F)
Input Power	20 to 30 Vdc. Reverse polarity and electrical transient protection provided
Hazardous Area Certification	Available safety certification for CSA & NRTL/C Class I (A, B, C & D) T4, Div. 2. ATEX/IECEX/UKCA, SIL See "Ordering Option H"
Electromagnetic Compatibility	Yes
Solid State Switches	100 mA, SPST, 120 VAC or 24 VDC
Electro-Mechanical Relays	SPDT 5A 240/120 VAC, resistive load 5A 24 VDC, resistive load
Reset	Momentary close (short) circuit to reset

WEIGHT & DIMENSIONS

Weight: 0.8 lbs (0.36 kg)
Maximum Power: 3.2W (5580), 4.0W (SW5580)
Recommended Wire Gauge: 0.8 mm² (18 AWG), Allowed: 0.2 to 1.3 mm² (16 to 24 AWG)
Relay Wiring: Solid State Relays - Allowed: 0.2 to 1.3 mm² (16 to 24 AWG), Electromechanical Relays - Allowed: 1.3mm² (16 AWG)
Mounting: 35mm DIN rail mounting
Casing Material: ABS PA765 Durable Plastic

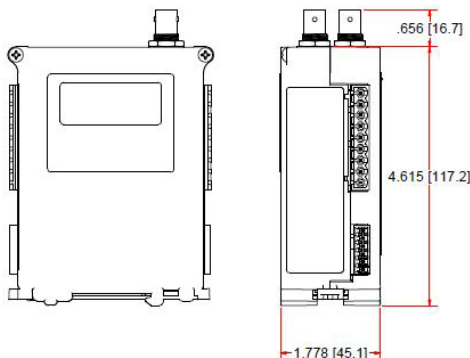
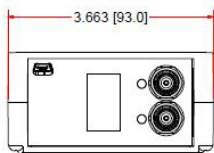

5580 Smart Signal Conditioner & SW5580 Dual Channel Configurable Switch

Datasheet



WARNING - DO NOT CONNECT OR DISCONNECT WHEN ENERGIZED. FIELD WIRING TO SIGNAL CONDITIONER/SMART SWITCH MUST COMPLY WITH LOCAL CODE. SIGNAL CONDITION PROVIDES INCREASED SAFETY CIRCUIT TO 5485C, SV6300 AND OTHER COMPATIBLE VELOCITY TRANSDUCERS AND SA6200A, SA6250 AND OTHER COMPATIBLE ACCELEROMETERS AND MX2033, MX2034 AND OTHER COMPATIBLE PROXIMITY SENSORS WHEN INSTALLED PER DRAWING NO. 1874437 (5580) & 1899690 (SW5580).

DO NOT APPLY POWER TO CHANNEL 2 TO AVOID DAMAGE. ONLY APPLY POWER TO CHANNEL 1.

5580 WIRING CONNECTIONS

PIN	Channel 1		Channel 2	
1	4-20mA +		4-20mA +	
2	4-20mA -		4-20mA -	
3	Raw signal out +		Raw signal out +	
4	Raw signal out -		Raw signal out -	
5	NC	PS	NC	PS
6	A/V +	PC	A/V +	PC
7	A/V -	PP	A/V -	PP
8	+	+24VDC	NC	
9	-		NC	

A/V – Accelerometer/Velocity Sensor
 PS – Proximity Signal
 PC – Proximity Common
 PP – Proximity Power
 NC – No Connection
 Reset – For Latching Alarms
 N.C. - Normally Closed
 N.O. - Normally Open

For barriers and isolators, see page 8, as well as the product manual (doc# 1874512).

SW5580 WIRING CONNECTIONS

PIN	Channel 1		Channel 2	
1	4-20mA +		4-20mA +	
2	4-20mA -		4-20mA -	
3	Raw signal out +		Raw signal out +	
4	Raw signal out -		Raw signal out -	
5	NC	PS	NC	PS
6	A/V +	PC	A/V +	PC
7	A/V -	PP	A/V -	PP
8	+	+24VDC	+	Reset
9	-		-	
	Dry Contacts	Solid State	Dry Contacts	Solid State
10	Alert N.O.	Alert +	Alert N.O.	Alert +
11	Alert N.C.	Not Used	Alert N.C.	Not Used
12	Alert Common	Alert -	Alert Common	Alert -
13	Danger N.O.	Danger +	Danger N.O.	Danger +
14	Danger N.C.	Not Used	Danger N.C.	Not Used
15	Danger Common	Danger Common	Danger Common	Danger Common

POSSIBLE MEASUREMENTS

- Shaft-relative radial vibration
- Shaft axial position (Thrust Measurements)
- Casing vibration (radial or axial)
- Shaft rotative speed
- Reciprocating compressor rod drop
- Reciprocating compressor rod position
- Reciprocating compressor crosshead acceleration
- Reciprocating machine impact measurements
- Reciprocating compressor frame vibration
- Dual Path measurements (two channel mode only)
 - One accelerometer input may generate an accelerometer output and an integrated velocity output
 - One accelerometer input may generate an accelerometer output and an impact output
 - One velocity input may generate a vibration output and an integrated position output
 - One proximity input may generate a position output (gap) and a vibration output
- Dual Channel measurements (two channel mode only)
 - Two acceleration inputs generates two acceleration outputs
 - Two acceleration inputs generates two impact outputs
 - One acceleration and one velocity input generates one acceleration and one velocity output
 - Two velocity inputs generates two velocity outputs
 - One velocity input and one proximity input generates one velocity and one proximity output (proximity output can be vibration, position or speed)

SAFETY INTEGRITY LEVEL

SIL is a method or measurement unit to determine the reliability of electrical, electronic and programmable systems. The purpose of the SIL certification is to measure safety system performance and the likelihood of failure. Achieving SIL certification, based on the IEC61508 Functional Safety Standard, signifies that the product has been thoroughly assessed and is a reliable electronic device ready to use across a wide range of industries.

Metrix products have been thoroughly evaluated by an independent third party agency on the basis of IEC61508 Functional Safety standards to obtain SIL certification.

ELECTROMAGNETIC COMPATABILITY (EMC)

EMC TEST REPORT (FULL COMPLIANCE)

Report Number: 104414010DAL-001 Project Number: G104414010

Report Issue Date: August 20, 2020

5580 Smart Vibration Signal Conditioner
SW5580 Dual Channel Configurable Switch

Standards:

CISPR 11:2009Ed.5+A1

Industrial, Scientific and Medical Equipment – Radio Frequency Disturbance Characteristics - Limits and Methods of Measurement

IEC 61000-4-4 Ed. 2.1:2011

Electromagnetic compatibility (EMC) - Part 4-4: Testing and measurement techniques - Electrical fast transient/burst immunity test

IEC 61000-4-6 Ed.3: 2008

Electromagnetic compatibility (EMC) - Part 4-6: Testing and measurement techniques - Immunity to conducted disturbances, induced by radio-frequency fields

NAMUR STANDARD

The NAMUR signal standard defines specific diagnostic meaning to values of current lying outside the 4-20 mA range: NAMUR compatible transmitters are designed to limit their output signals between 3.8 mA and less than 21 mA when functioning properly. If the sensor is not functioning properly the sensor will go Not OK (< 3.6 mA).

5580 Smart Signal Conditioner & SW5580 Dual Channel Configurable Switch

Datasheet

ORDERING INFORMATION

5580 Smart Signal Conditioner									
Channel 1					Channel 2				
5580-A-B-CCCC-D-E-FFFF-GG-H-					B-CCCC-D-E-FFFF-GG				
5580-□-□-□□□□-□-□-□□□□-□□-□-□					□-□□□□-□-□-□□□□-□□				
SW5580 Dual Channel Configurable Switch									
Channel 1					Channel 2				
SW5580-A-B-CCCC-D-E-FFFF-GG-H-J-					B-CCCC-D-E-FFFF-GG				
SW5580-□-□-□□□□-□-□-□□□□-□□-□-□					□-□□□□-□-□-□□□□-□□				
A	Channel Configuration								
1	Channel 1 Only ¹								
2	Channel 1 and Channel 2 ²								
3	Enable Channel 2 On Site ³								
B	Input Signal Type								
1	Velocity Sensor								
2	Accelerometer								
3	Proximity Probe System								
CCCC	Full Scale Range								
FFFF (If B=1)				Sensor Input in mV/ips (mV/mm/s)					
1	0	0	V	100 mV/ips (3.9 mV/mm/s)				SV6300A recommended	
1	0	5	V	105 mV/ips (4.1 mV/mm/s)				5485C recommended	
1	4	5	V	145 mV/ips (5.7mV/mm/s)					
1	5	0	V	150 mV/ips (5.9 mV/mm/s)					
2	0	0	V	200 mV/ips (7.9 mV/mm/s)					
5	0	0	V	500 mV/ips (19.7 mV/mm/s)					
CCCC (If B=1)				Sensor Input Type/ Mounting Style/ Range Code					
Input Velocity Sensor Type				Vibration Range (4-20 mA Output)				Output Measure	
Electro-Mechanical Velocity Sensor		Piezoelectric Velocity Sensor							
1	0	2	V	5	0	2	V	0 - 1.0 ips, pk	
1	3	2	V	5	3	2	V	0 - 1.0 ips, rms	
1	0	3	V	5	0	3	V	0 - 2.0 ips, pk	
1	3	3	V	5	3	3	V	0 - 2.0 ips, rms	
1	0	4	V	5	0	4	V	0 - 3.0 ips, pk	
1	3	4	V	5	3	4	V	0 - 3.0 ips, rms	
1	0	5	V	5	0	5	V	0 - 10 mils, pk-pk	
1	0	6	V	5	0	6	V	0 - 20 mils, pk-pk	

NOTES:

1. If only channel configuration "1" is entered in the order, channel 2 will be disabled by manufacturer, but can be enabled from the configuration software with additional fee.
2. If channel configuration "2" is entered in the order, both channels will be enabled by manufacturer.
3. Channel configuration "3" cannot be ordered without channel configuration "1" having been ordered first. With an additional fee, Metrix will ship a passcode. User can enable channel 2 from the configuration software.
4. This range can only be used for FFF option 500A = 500 mV/g (51 mV/m/s²)

3	0	2	V	7	0	2	V	0 - 20 mm/s, pk		Velocity/ Metric System
3	3	2	V	7	3	2	V	0 - 20 mm/s, rms		
3	0	3	V	7	0	3	V	0 - 50 mm/s, pk		
3	3	3	V	7	3	3	V	0 - 50 mm/s, rms		Integrated Displacement/ Metric System
3	0	5	V	7	0	5	V	0 - 200 um, pk-pk		
3	0	6	V	7	0	6	V	0 - 500 um, pk-pk		
				1 mm/s = 0.03937 ips		1 ips = 25.4 mm/s				
				1 mil = 25.4 μm		1 μm = 0.03937 mil				
CCCC (If B=2)				Sensor Input Type/ Mounting Style/ Range Code						
Accel sensor (Input)				Vibration Range (4-20 mA Output)				Output Measure/ Unit System		
DIN rail										
1	1	0	A	0 - 1 g, pk ⁴				Acceleration/ English System		
1	1	1	A	0 - 2 g, pk ⁴						
1	4	0	A	0 - 1 g, rms ⁴						
1	4	1	A	0 - 2 g, rms ⁴						
1	0	2	A	0 - 10 g, pk						
1	3	2	A	0 - 10 g, rms						
1	0	7	A	0 - 50 g, pk						
1	3	7	A	0 - 35 g, rms						
1	0	5	A	0 - 1.0 ips, pk				Integrated Velocity/ English System		
1	3	5	A	0 - 1.0 ips, rms						
1	0	6	A	0 - 2.0 ips, pk						
1	3	6	A	0 - 2.0 ips, rms						
3	0	2	A	0 - 100 m/s ² , pk				Acceleration/ Metric System		
3	3	2	A	0 - 100 m/s ² , rms						
3	0	3	A	0 - 200 m/s ² , pk						
3	3	3	A	0 - 200 m/s ² , rms						
3	0	7	A	0 - 500 m/s ² , pk						
3	3	7	A	0 - 350 m/s ² , rms						
3	1	0	A	0 - 10 m/s ² , pk						
3	1	1	A	0 - 20 m/s ² , pk ⁴						
3	4	0	A	0 - 10 m/s ² , rms				Integrated Velocity/ Metric System		
3	4	1	A	0 - 20 m/s ² , rms						
3	0	5	A	0 - 20 mm/s, pk						
3	3	5	A	0 - 20 mm/s, rms						
3	0	6	A	0 - 50 mm/s, pk						
3	3	6	A	0 - 50 mm/s, rms						



5580 Smart Signal Conditioner & SW5580 Dual Channel Configurable Switch

Datasheet

CCCC (IF B=3)				Proximity Probe System Type
0	0	2	P	4 mils, pk-pk (Vibration)
0	0	3	P	5 mils, pk-pk (Vibration)
0	0	4	P	6 mils, pk-pk (Vibration)
0	0	5	P	10 mils, pk-pk (Vibration)
0	0	6	P	15 mils, pk-pk (Vibration)
0	0	7	P	20 mils, pk-pk (Vibration)
CCCC (IF B=3)				Proximity Probe System Type
0	0	2	P	4 mils, pk-pk (Vibration)
0	0	3	P	5 mils, pk-pk (Vibration)
0	0	4	P	6 mils, pk-pk (Vibration)
0	0	5	P	10 mils, pk-pk (Vibration)
0	0	6	P	15 mils, pk-pk (Vibration)
0	0	7	P	20 mils, pk-pk (Vibration)
0	0	8	P	30 mils, pk-pk (Vibration)
0	0	9	P	40 mils, pk-pk (Vibration)
0	2	1	P	100 μm, pk-pk (Vibration)
0	2	2	P	150 μm, pk-pk (Vibration)
0	2	3	P	200 μm, pk-pk (Vibration)
0	2	4	P	250 μm, pk-pk (Vibration)
0	2	5	P	300 μm, pk-pk (Vibration)
0	2	6	P	400 μm, pk-pk (Vibration)
0	2	7	P	500 μm, pk-pk (Vibration)
0	2	8	P	750 μm, pk-pk (Vibration)
0	2	9	P	1000 μm, pk-pk (Vibration)
0	5	0	P	30-70 mils, avg gap (Position)
0	5	1	P	20-80 mils, avg gap (Position)
0	5	2	P	10-90 mils, avg gap (Position)
CCCC (IF B=3)				Proximity Probe System Type Continued
0	5	3	P	10-50 mils, avg gap (Position)
0	5	4	P	20-70 mils, avg gap (Position)
0	5	5	P	10-60 mils, avg gap (Position)
0	5	6	P	10-70 mils, avg gap (Position)
0	5	7	P	20-160 mils, avg gap (Position)
0	5	8	P	20-180 mils, avg gap (Position)
0	7	0	P	750-1750 μm, avg gap (Position)
0	7	1	P	500-2000 μm, avg gap (Position)
0	7	2	P	250-2250 μm, avg gap (Position)
0	7	3	P	250-1250 μm, avg gap (Position)
0	7	4	P	500-1750 μm, avg gap (Position)
0	7	5	P	250-1500 μm, avg gap (Position)
0	7	7	P	500-4000 μm, avg gap (Position)
0	7	8	P	500-4500 μm, avg gap (Position)

					Events Per Rev.
5	0	1	P	500 RPM (Speed)	1-99 (All)
2	0	2	P	2000 RPM (Speed)	1-99 (All)
3	6	2	P	3600 RPM (Speed)	1-99 (All)
4	0	2	P	4000 RPM (Speed)	1-95
5	0	2	P	5000 RPM (Speed)	1-52
6	0	2	P	6000 RPM (Speed)	1-47
7	5	2	P	7500 RPM (Speed)	1-38
1	0	3	P	10000 RPM (Speed)	1-31
1	5	3	P	15000 RPM (Speed)	1-25
5	0	3	P	50000 RPM (Speed)	1-19
6	0	3	P	60000 RPM (Speed)	1-2
7	5	3	P	75000 RPM (Speed)	1-3
1	0	4	P	100000 RPM (Speed)	1-3
CCCC (IF B=2)		Impact Measurement Type ¹			
0	0	1	I	INPUT <= 900 [mV PK] (IMPACT)	
0	0	2	I	INPUT <= 1400 [mV PK] (IMPACT)	
0	0	3	I	INPUT <= 2500 [mV PK] (IMPACT)	
0	0	4	I	INPUT <= 4750 [mV PK] (IMPACT)	

D	E	Bandpass Filter ^{2,3}
0	0	None
1	1	2-200 Hz
1	2	2-1500 Hz
1	3	2-2000 Hz
1	4	2-10k Hz
1	7	2-500 Hz
1	18	2-2100 Hz
1	21	2-4000 Hz
3	5	300-1800 Hz
4	6	500-2500 Hz
5	7	10-500 Hz
6	8	25-75 Hz
7	9	30-120 Hz

D	E	Bandpass Filter ^{2,3}
8	10	75-125 Hz
9	11	125-175 Hz
10	12	175-225 Hz
11	13	225-275 Hz
12	14	275-325 Hz
13	15	325-375 Hz
14	16	375-425 Hz
15	17	425-475 Hz
16	3	110-2000 Hz
17	3	50-2000 Hz
17	19	50-150 Hz
18	7	100-500 Hz
19	20	40-300 Hz

Ordering Example: 5580-1-2-102A-14-100A-0

Channel 1, Accelerometer input, DIN-rail with 0-10 g pk range, filter from 2 Hz-10 KHz, 100 mV/g sensor input, no hazard area certification.

Ordering Example: SW5580-1-2-102A-00-025A-0-2

Channel 1, Accelerometer input, DIN-rail with 0-10 g pk range, no filter, 25 mV/g sensor input, no hazard area certification, and electromechanical relays.

Ordering Example: 5580-2-2-102A-23-100A-00-5-2-105A-11-100A-00

Channel 1, Accelerometer input, DIN-rail with 0-10 g pk range, filter from 200 Hz-2000 Hz, 100 mV/g sensor input, no pulses for speed, hazardous area certification.

Channel 2, Acceleration input, 0-1 ips pk velocity output, filtered from 2 Hz-200 Hz, no pulses for speed.



5580 Smart Signal Conditioner & SW5580 Dual Channel Configurable Switch

Datasheet

FFFF (If B=1)				Sensor Input in mV/ips (mV/mm/s)	
1	0	0	V	100 mV/ips (3.9 mV/mm/s)	SV6300A recommended
1	0	5	V	105 mV/ips (4.1 mV/mm/s)	5485C recommended
1	4	5	V	145 mV/ips (5.7mV/mm/s)	
1	5	0	V	150 mV/ips (5.9 mV/mm/s)	
2	0	0	V	200 mV/ips (7.9 mV/mm/s)	
5	0	0	V	500 mV/ips (19.7 mV/mm/s)	
FFFF (If B=2)				Sensor Input in mV/g (mV/mm/s ²)	
0	1	0	A	10 mV/g (1 mV/m/s ²)	
0	2	5	A	25 mV/g (2.55 mV/m/s ²)	
0	5	0	A	50 mV/g (5.10 mV/m/s ²)	
1	0	0	A	100 mV/g (10.20 mV/m/s ²)	
5	0	0	A	500 mV/g (51 mV/m/s ²)	

FFFF (If B=2)				Sensor Input in mV/g (mV/mm/s ²)	
0	1	0	A	10 mV/g (1 mV/m/s ²)	
0	2	5	A	25 mV/g (2.55 mV/m/s ²)	
0	5	0	A	50 mV/g (5.10 mV/m/s ²)	
1	0	0	A	100 mV/g (10.20 mV/m/s ²)	
5	0	0	A	500 mV/g (51 mV/m/s ²)	
FFFF (If B=3)				Driver Output in mV/mil (mV/μm)	
1	0	0	P	100mV/mil (3.937 mV/μm)	
2	0	0	P	200mV/mil (7.87 mV/μm)	

NOTES:

1. The Maximum Input for the Impact Measurement can be estimated based on the amplitude of an accelerometer monitoring the reciprocating compressor crosshead. This example assumes an accelerometer with 100mV/g (10.2 mV/m/sec²) scale factor. The Maximum Input should include 5 times the measured acceleration value. For example: If the accelerometer from your portable data collector is mounted on the crosshead of an operating reciprocating compressor, and the acceleration reads 350 mV pk, one would choose < 2500 mV pk (350 mV x 5 = 1750 mV pk).
2. Standard is D-E=0-0; Bandpass Filters affect 4-20 mA output but have no effect on dynamic output. For the impact measurement type, D-E filters must be 0-0.
3. If both channels are enabled, changing the filter options on channel 1 (DE1) will limit the filter options for channel 2 (DE2). See Table 1.

GG		Pulses per Revolution
0	0	N/A (for vibration or position), Accelerometer or Velocity Input
X	X	XX=Number of pulses per revolution (events per revolution), valid entries are two digit numbers from 01-99, with a maximum value of RPM x # of events ≤ 190,000. These two digits are relevant to proximity speed mode only.
H		Hazardous Area Certification*
0		Ordinary Location Approval (Non-Hazardous Area Approval)
5		Multiple Hazardous Area Approvals ^{6,7,8}
J		Relay Circuit Output ⁹
1		Solid-state switch (SPST, 100 mA, 120 VAC or 24 VDC)
2		Electromechanical relay (SPDT, 5A 240/120 VAC resistive load, or 5A 24 VDC resistive load)

NOTES:

- 6. When connected & wired w/approved Metrix sensor. Request Application Wiring Drawing 1874437 for details. If sensors are rated for Class I Div 1 or Zone 0 or 1 as long as the 5580/SW5580 remains in an approved area with barriers this is allowed. See page 8 for details.
- 7. ETL, ATEX, IECEx, hazardous area approvals. See page 8 for details.
- 8. When using a proximity sensor with a barrier a 6KΩ resistor will need to be placed between pins 7 and 8 (the barrier supplies power to the MX2033 driver, but the 5580/SW5580 circuit needs to see a load on the proximity power (pin 7 PWR) to the driver in order to not go “Not OK”). See page 8 for details.
- 9. Relay setpoint defaults are set at 25% and 50% of the full scale range and associated time delays are set at 3 seconds.

*For SIL approval, add an “S” prefix to the desired Hazardous Area Certification (Option H)

IMPACT MEASUREMENT

The impact measurement uses an accelerometer input and outputs a 4-20 mA signal proportional to the number of impact events over the threshold in a set time period. The relationship between the mA signal and the number of impact events remains the same. The time frame (reset time) over which the events are measured can be changed using the 5580/SW5580 software. This allows you to match the measuring time frame with the RPM range of your equipment. Chart #1 indicates mA output vs. impact events over the set threshold.

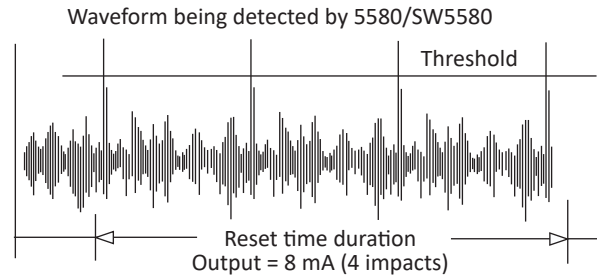







CHART 1	
Severity Level	Output
16 impacts > threshold	20 mA
14 impacts > threshold	18 mA
12 impacts > threshold	16 mA
10 impacts > threshold	14 mA
8 impacts > threshold	12 mA
6 impacts > threshold	10 mA
4 impacts > threshold	8 mA
2 impacts > threshold	6 mA
No impacts > threshold	4 mA
Loss of Power	0 mA

Translates number of impact events into 4-20 mA signal

HAZARDOUS AREA APPROVALS

AREA	5580	SW5580
North America	<p>CLASS I, DIVISION 2, GROUPS A, B, C & D, CLASS I, ZONE 2, AEx ec nC IIC T4 Gc -40°C ≤Ta≤ +85°C ETL20CA104377470X Increased Safety</p> 	<p>CLASS I, DIVISION 2, GROUPS A, B, C & D, CLASS I, ZONE 2, AEx ec nC IIC T4 Gc -40°C ≤Ta≤ +65°C ETL20CA104377470X Increased Safety</p> 
International ATEX/IECEX/UKEX	<p> Ex ec nC IIC T4 Gc -40°C ≤Ta≤ +85°C II 3 G ITS-I21ATEX30380X IECEX ETL 21.0036X ITS21UKEX0213X Increased Safety</p> 	<p> Ex ec nC IIC T4 Gc -40°C ≤Ta≤ +65°C II 3 G ITS-I21ATEX30380X IECEX ETL 21.0036X ITS21UKEX0213X Increased Safety</p> 

Note: Metrix is continuously improving our products. Please refer to our website to download the latest version of this document.

© 2026, Metrix Instrument Company, L.P. All rights reserved.