

## MX5000 Monitoring of Induced Draft and Forced Draft Fan Applications

### Condition Monitoring of Induced Draft Fans and Forced Draft Fans

#### Overview

Induced Draft (ID) and Forced Draft (FD) fans play a critical role in industrial operations, particularly in coal-fired power plants and other combustion-based processes. These machines are not simply auxiliary equipment, they are fundamental to maintaining combustion stability, controlling airflow, and ensuring safe and efficient plant performance.

Forced Draft fans are responsible for supplying combustion air to boilers or furnaces, while Induced Draft fans extract flue gases and maintain negative pressure within the system. Together, they regulate airflow through the combustion process, directly influencing thermal efficiency, emissions compliance, and overall plant output.

Given their importance, any degradation in fan performance can have immediate operational consequences. Failures may lead to unit derates, unsafe pressure conditions, emissions exceedances, or even complete plant outages. For this reason, robust condition monitoring is essential for maintaining reliability and avoiding costly disruptions.

#### Operating Characteristics and Monitoring Challenges

Large ID and FD fans often operate at high horsepower and moderate speeds, typically



**Forced Draft Fan**

supported by fluid film bearings (sleeve bearings) or heavy-duty rolling element bearings. Due to the mass of the impeller and ducting forces, they are highly sensitive to rotor dynamic issues, aerodynamic loading changes, and structural looseness.

These machines experience continuous exposure to changing operating conditions such as fluctuating airflow demand, temperature variations, and contamination from particulate matter. Over time, these factors introduce imbalances, structural stresses, and aerodynamic instabilities that can significantly impact performance.

Reliable vibration and temperature monitoring is therefore essential to ensure continuous, safe, and efficient operation.

#### Common Failure Modes in Draft Fans

##### Rotor Unbalance

One of the most prevalent issues in ID and FD fans is rotor unbalance, which occurs when the mass centerline of the rotor does not align with

its rotational axis. In induced draft systems, this condition is often caused by ash or particulate buildup on fan blades, while in forced draft systems, erosion and wear can shift mass distribution.

Unbalance typically manifests as elevated vibration at the fundamental running speed (1X), accompanied by a stable phase angle and increasing radial vibration amplitude. If left uncorrected, it can accelerate bearing degradation and contribute to fatigue damage in blades and shafts.

### Misalignment

Misalignment between the motor and fan shafts is another common fault, often resulting from thermal expansion differences, foundation movement, or improper installation. This condition produces elevated axial and radial vibration, with characteristic frequency components at 1X and 2X running speed.

In addition to increased vibration levels, misalignment frequently leads to higher bearing temperatures and excessive thrust loading. Over time, this reduces coupling life and increases the risk of secondary mechanical failures.

### Rotor-to-Stator Rubs

Rotor-to-stator contact can occur due to excessive shaft movement, worn bearings, or improper clearances following maintenance. These events are typically abrupt and damaging, producing sudden spikes in vibration, broadband frequency increases, and rapid temperature rise.

Early detection of rub conditions is critical, as prolonged contact can severely damage both rotor and casing components, leading to costly repairs and extended downtime.

### Fluid-Induced Instabilities (Fluid Film Bearings)

Fans equipped with fluid film bearings are susceptible to dynamic instabilities such as oil whirl and oil

whip. These phenomena are characterized by sub-synchronous vibration (typically below half the running speed) and circular shaft motion.

Such instabilities can amplify as the system approaches critical speeds, potentially leading to catastrophic failure if not properly identified and mitigated. Monitoring shaft position, orbit patterns, and phase relationships is essential for diagnosing these conditions.

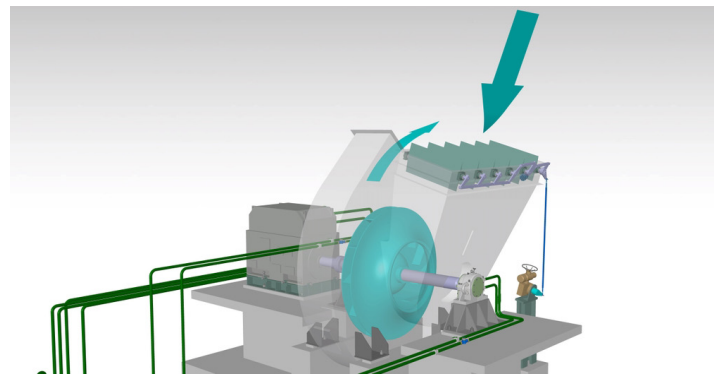

**Induced Draft Fan**

### Aerodynamic Instability & Surge

In addition to mechanical faults, draft fans are vulnerable to aerodynamic instabilities caused by flow separation or operating outside optimal performance regions. These conditions can result in surge, fluctuating loads, and unstable operation

Aerodynamic issues are particularly challenging because they are influenced by process conditions rather than purely mechanical factors. As a result, they require integrated monitoring that considers both vibration and process variables to provide a more complete diagnostic picture.

### Structural Looseness

Structural looseness is a common issue in large fan systems, which extend beyond the rotating assembly to include ductwork, expansion joints, baseplates, and structural supports. Over time, factors such as vibration fatigue, thermal expansion, and mechanical

wear can degrade these connections, reducing overall system stiffness. As a result, the structural integrity of the installation is compromised, allowing excessive movement that can influence the dynamic behavior of the fan and associated components.

This condition introduces complex vibration signatures that can be difficult to interpret. Looseness often appears as elevated vibration at running speed (1X) along with harmonic content, indicating mechanical instability or repeated movement within the structure. In more severe cases, random broadband vibration and intermittent impacting signatures may be observed, reflecting uncontrolled motion or contact between loosened elements. Effective monitoring is essential to distinguish these structural issues from rotor-related faults such as unbalance or misalignment, enabling accurate diagnosis and appropriate corrective action.

### Motor Defects

Motor defects in draft fan systems often originate from electrical issues within the motor itself, including broken rotor bars, rotor eccentricity, and degradation of stator windings. These faults disrupt the uniformity of the electromagnetic field within the motor, leading to an uneven air gap and the development of unbalanced magnetic forces. As a result, the motor can experience abnormal mechanical stresses that manifest as vibration anomalies during operation.

These defects not only affect motor efficiency but can also accelerate wear on connected components such as couplings and fan shafts. Early detection is critical, and techniques such as motor current signature analysis (MCSA), combined with vibration trending, provide valuable insight into developing issues. By identifying characteristic frequency patterns and tracking changes over time, maintenance teams can diagnose electrical faults before they progress into more severe mechanical failures.

## Instrumentation Suite for Condition Monitoring

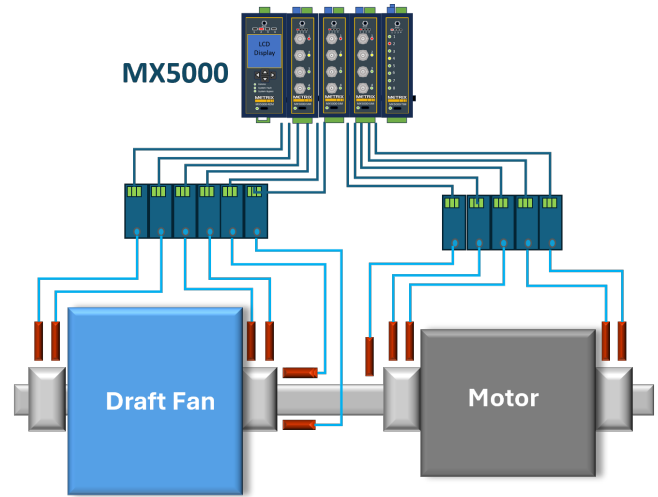

Typical Instrumentation

The appropriate instrumentation suite can provide early warning of the malfunctions listed above through vibration, temperature, and process parameter monitoring.

### Vibration Sensors (Proximity Probes, Velocity Sensors, Accelerometers)

These sensors detect changes in amplitude, frequency, and phase indicative of developing faults:

- Proximity Probes measure shaft displacement, orbit, and phase (ideal for sleeve bearings).
- Velocity Sensors provide overall vibration severity per ISO standards.
- Accelerometers detect high-frequency faults such as bearing defects and structural looseness.

### Axial Position (Thrust) Monitoring

These sensors detect changes in amplitude, frequency, and phase indicative of developing faults:

- Detecting excessive thrust load
- Identifying coupling issues
- Preventing contact with internal components

## Temperature Monitoring

Temperature increases often precede mechanical failure:

- Bearing metal temperature
- Oil temperature (if applicable)
- Motor stator winding temperature

## Motor Current Monitoring

Correlating current with vibration improves diagnostic confidence. Motor current sensors help identify:

- Electrical imbalance
- Rotor defects
- Load variations

## Pressure and Flow Monitoring

For ID/FD fans, process variables are critical:

- Inlet pressure
- Outlet pressure
- Differential pressure
- Airflow rate

Combining process and vibration data enables detection of aerodynamic instability or surge.

## Critical ID/FD Fan Monitoring Configuration

Large ID and FD fans with fluid film bearings require continuous monitoring.

Metrix recommends the following instrumentation suite for **fluid film bearing fans**:

- XY radial proximity probes at each sleeve bearing
- 2 Axial position (thrust) sensors
- 1 Phase trigger (speed reference)
- 4 Bearing temperature sensors
- 2 Motor winding temperature sensors

Metrix recommends the following instrumentation suite for **rolling element bearing fans**:

- Dual radial accelerometers or velocity sensors per bearing
- Axial vibration sensor

- Bearing temperature sensors
- Phase reference

## Typical MX5000 Monitoring System for ID/FD Fan



**MX5000 Monitoring System**

The MX5000 modular architecture allows scalable configuration tailored to the machine.

The heart of the MX5000 is the Sensor Interface Module (SIM). Each four-channel monitor can be combined to create a comprehensive monitoring system for critical rotating equipment.

The system integrates easily into plant DCS, PLC, or historian systems for real-time trending and alarm management as well as portable analysis devices for detailed diagnostics of machinery condition.

The typical monitoring system includes:

- One Rack Emulation Module (REM)
  - API 670-style rack functions
  - Mechanical relays
  - Bypass, reset, trip multiply
- Sensor Interface Modules (SIM)
  - Four channels each
  - 4–20 mA outputs per channel
  - Modbus communication
  - Buffered Signal Output for each channel
- Temperature Interface Module (TIM)
  - Eight temperature inputs
  - Solid-state relays
  - Integration with SIM/REM

## Case History

### Power Plant Example

#### Early Detection Using Portable Diagnostics

In a 500-MW coal-fired power plant, an induced draft fan began exhibiting elevated vibration levels shortly after startup following a planned outage. The vibration amplitude quickly exceeded alarm thresholds, raising concerns about a potential trip and its impact on plant operations. To investigate the issue, a portable data collector was connected directly to the MX5000 system's BNC outputs, allowing for detailed analysis of the fan's dynamic behavior.

#### Identifying Unbalance Through Orbit and Spectrum Analysis

The collected data showed a clear diagnostic signature: a dominant 1X running speed vibration component, a stable phase angle, and no observable shift in resonant frequency. This combination of indicators pointed away from structural or resonance-related issues and instead suggested a classic rotor unbalance condition. A subsequent inspection confirmed the root cause—ash accumulation on one quadrant of the impeller, likely introduced or redistributed during the outage period.

#### Avoiding Significant Downtime and Operational Loss

Once the buildup was removed and the rotor was field balanced, vibration levels returned to acceptable operating limits. While the corrective action itself was straightforward, the implications of missing this condition would have been significant. A trip of the induced draft fan would have forced a full unit shutdown, and at an estimated value of \$40 per megawatt-hour, even a single day of downtime would have resulted in substantial lost revenue.

This example highlights the value of early detection and accurate diagnosis. By leveraging real-time data and advanced analysis, the issue was resolved

before it could escalate into a forced outage or cause secondary damage to critical components such as bearings and seals.

### Refinery Example

#### Early Detection of Thermal-Induced Misalignment

In a refinery application, a forced draft (FD) fan began showing a gradual increase in axial vibration along with a noticeable shift in thrust position. Unlike sudden faults, this was a slow-developing condition captured through continuous monitoring, which revealed a clear trend over time rather than a single event. The data pointed to progressive coupling misalignment, driven by thermal growth differences between the motor and fan during normal operating conditions—an issue that often emerges as systems heat up and components expand at different rates.

#### Planned Maintenance vs. Reactive Shutdown

Rather than reacting to an alarm or failure, the monitoring system enabled a proactive response. Maintenance teams were able to diagnose the root cause early and plan corrective action during a scheduled turnaround. This avoided the need for an emergency shutdown, prevented production losses, and eliminated the safety risks associated with unstable furnace pressure—particularly critical in refinery environments where airflow control directly affects combustion stability.

#### Economic Value of Predictive Monitoring

This example underscores the broader economic importance of monitoring ID and FD fans. These machines are integral to combustion and emissions control, and their failure can trip boilers, reduce steam production, and trigger regulatory penalties. Even a single day of unplanned downtime can have significant financial consequences. In practice, if predictive monitoring prevents just one such event over several years, the investment in vibration monitoring delivers rapid and measurable value—

often paying for itself after the first avoided incident.

## Conclusion

Induced Draft and Forced Draft fans are mission-critical assets that directly influence combustion efficiency, process stability, and regulatory compliance across a wide range of industrial applications. Given their central role, even minor deviations in performance can quickly escalate into operational risks, making continuous and reliable monitoring indispensable.

The MX5000 monitoring system addresses these challenges by combining API 670-style protection with continuous condition monitoring in a flexible, modular architecture. By integrating vibration, temperature, and process measurements into a single

platform, it provides operators with a unified and comprehensive view of machine health. This holistic approach enables early fault detection, precise diagnostics, and timely intervention—reducing the likelihood of unexpected failures and optimizing maintenance strategies.

Ultimately, the value of the MX5000 lies in its ability to transform raw data into actionable insight. By continuously tracking parameters such as shaft vibration, casing vibration, axial position, and temperature, it empowers teams to move from reactive troubleshooting to proactive asset management. The result is improved safety, enhanced reliability, and sustained operational performance—ensuring that critical draft fan systems continue to operate efficiently throughout their lifecycle.

**Note:** Metrix is continuously improving our products. Please refer to our website to download the latest version of this document.

All trademarks, service marks, and/or registered trademarks used in this document belong to Metrix Instrument Company, L.P.

© 2026, Metrix Instrument Company, L.P. All rights reserved.